

# Lecture 21: Generative Models

# Supervised vs Unsupervised Learning

## Supervised Learning

**Data:**  $(x, y)$

$x$  is data,  $y$  is label

**Goal:** Learn a *function* to map  $x \rightarrow y$

**Examples:** Classification, regression, object detection, semantic segmentation, image captioning, etc.

## Unsupervised Learning

**Data:**  $x$

Just data, no labels!

**Goal:** Learn some underlying hidden *structure* of the data

**Examples:** Clustering, dimensionality reduction, density estimation, etc.

# Generative Modeling

Given training data, generate new samples from same distribution

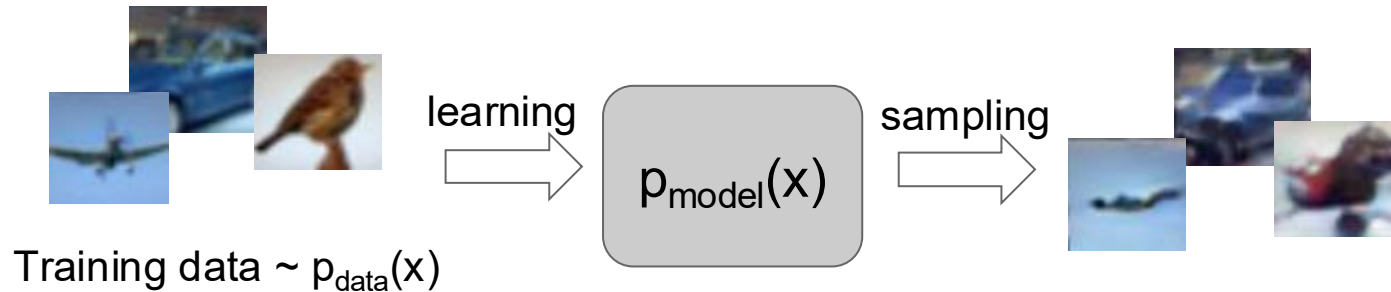

Objectives:

1. Learn  $p_{\text{model}}(x)$  that approximates  $p_{\text{data}}(x)$
2. **Sampling new  $x$  from  $p_{\text{model}}(x)$**

# Generative Modeling

Given training data, generate new samples from same distribution

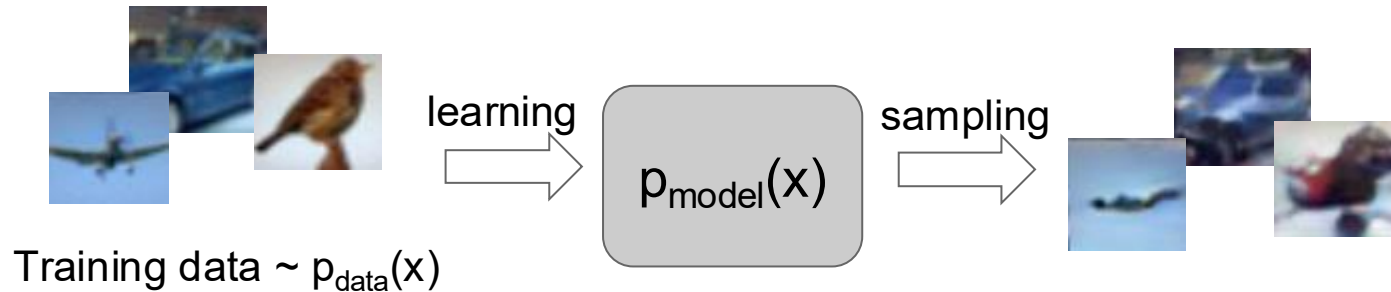

Formulate as density estimation problems:

- **Explicit density estimation:** explicitly define and solve for  $p_{\text{model}}(x)$
- **Implicit density estimation:** learn model that can sample from  $p_{\text{model}}(x)$  **without explicitly defining it.**

# Why Generative Models?



- Realistic samples for artwork, super-resolution, colorization, etc.
- Learn useful features for downstream tasks such as classification.
- Getting insights from high-dimensional data (physics, medical imaging, etc.)
- Modeling physical world for simulation and planning (robotics and reinforcement learning applications)
- Many more ...

Figures from L-R are copyright: (1) [Alex Radford et al. 2016](#); (2) [Phillip Isola et al. 2017](#). Reproduced with authors permission (3) [BAIR Blog](#).

# Taxonomy of Generative Models

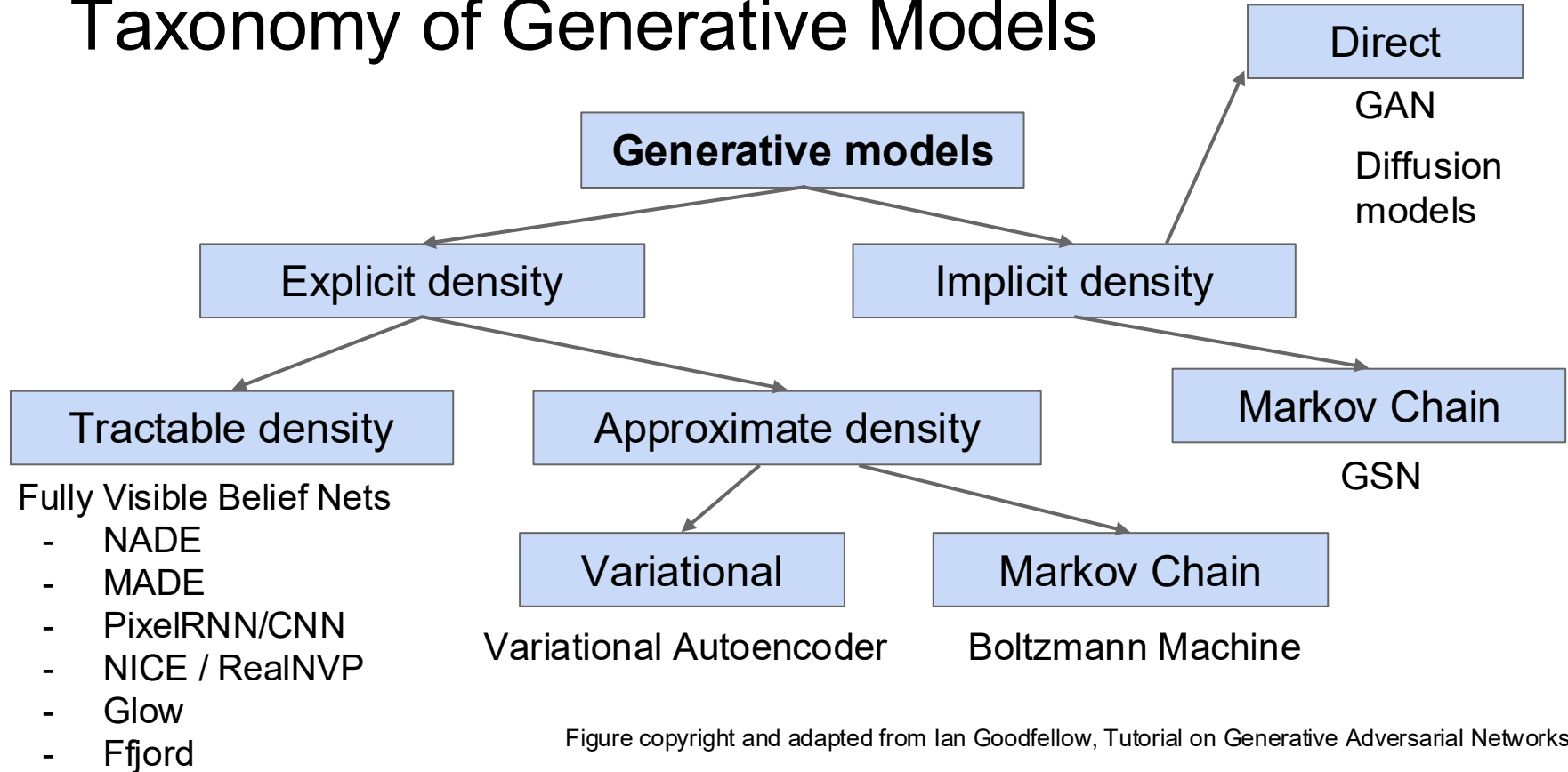

Figure copyright and adapted from Ian Goodfellow, Tutorial on Generative Adversarial Networks, 2017.

# Taxonomy of Generative Models

Today: discuss 3 most popular types of generative models today

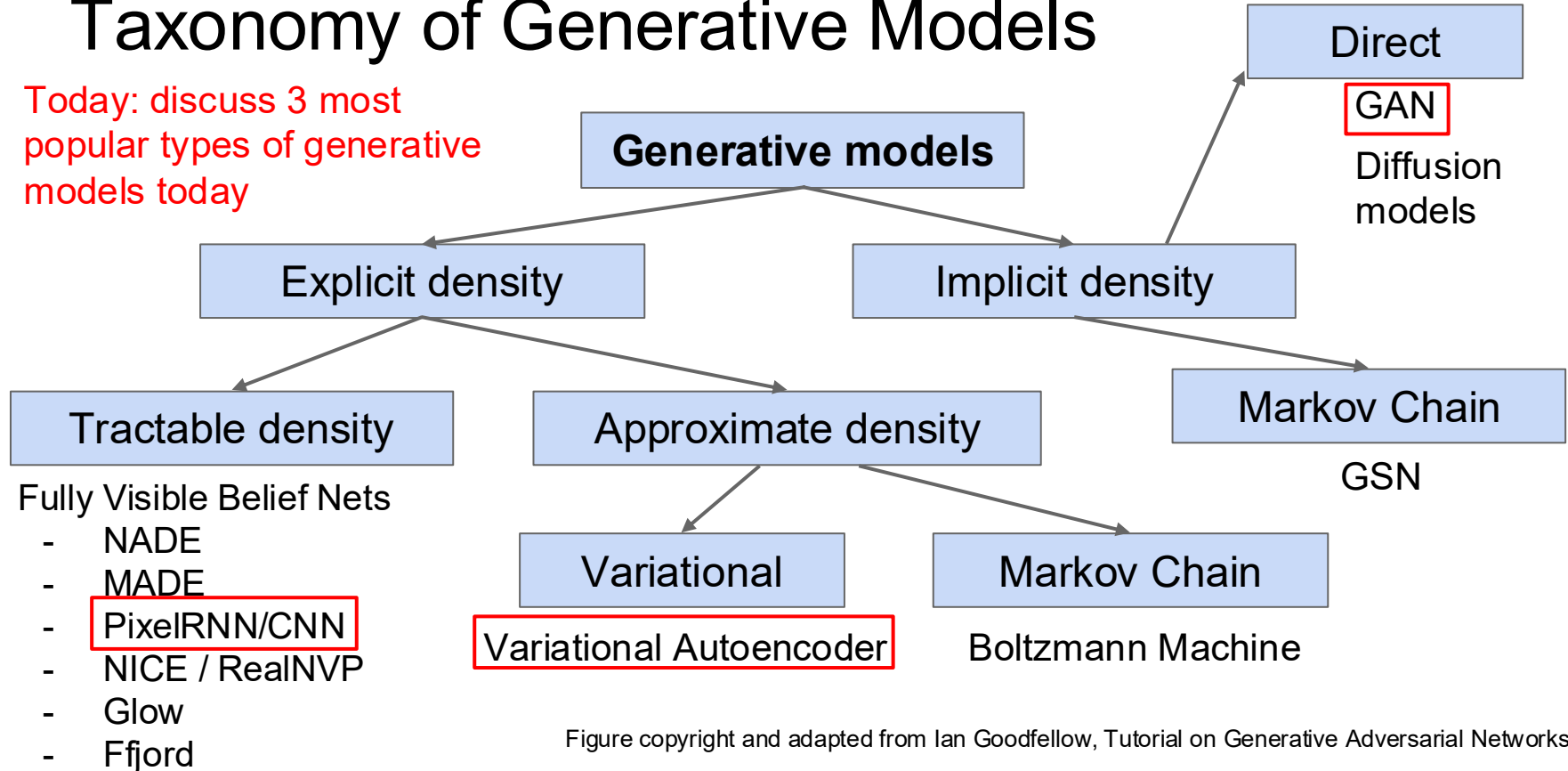

Figure copyright and adapted from Ian Goodfellow, Tutorial on Generative Adversarial Networks, 2017.

# PixelRNN and PixelCNN

(A very brief overview)

# Fully visible belief network (FVBN)

Explicit density model

$$p(x) = p(x_1, x_2, \dots, x_n)$$

↑  
Likelihood of  
image  $x$

↑  
Joint likelihood of each  
pixel in the image



# Fully visible belief network (FVBN)

Explicit density model

Use chain rule to decompose likelihood of an image  $x$  into product of 1-d distributions:

$$p(x) = \prod_{i=1}^n p(x_i | x_1, \dots, x_{i-1})$$

↑  
Likelihood of  
image  $x$

↑  
Probability of  $i$ 'th pixel value  
given all previous pixels

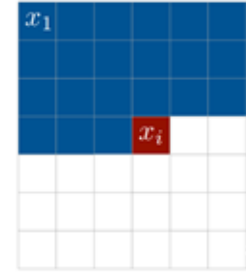

Complex distribution over pixel  
values => Express using a neural  
network!

Then maximize likelihood of training data

# Recurrent Neural Network

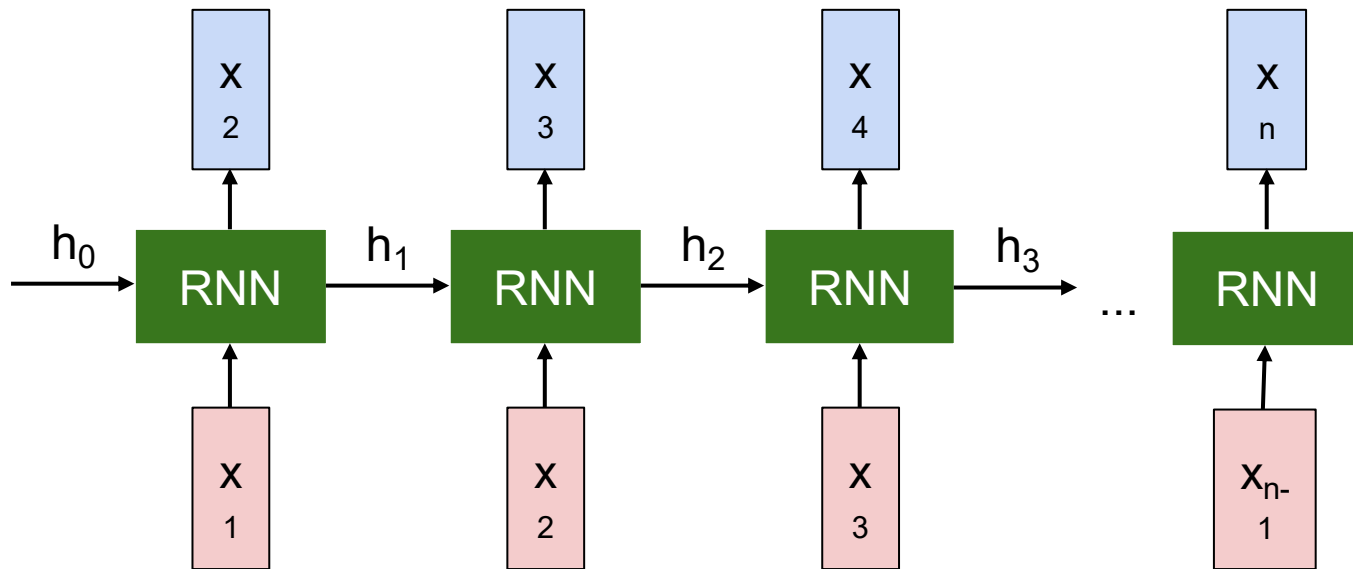

$$p(x_i | x_1, \dots, x_{i-1})$$

# PixelRNN *[van der Oord et al. 2016]*

Generate image pixels starting from corner

Dependency on previous pixels modeled using an RNN (LSTM)

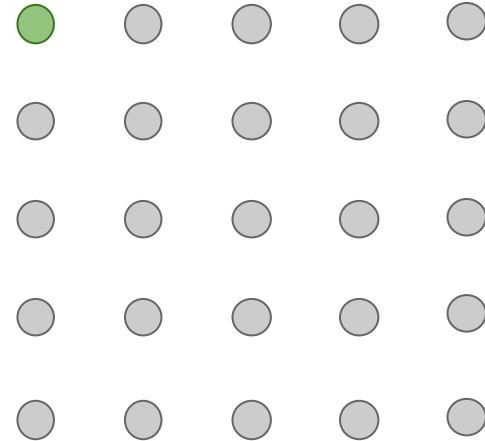

# PixelRNN *[van der Oord et al. 2016]*

Generate image pixels starting from corner

Dependency on previous pixels modeled using an RNN (LSTM)

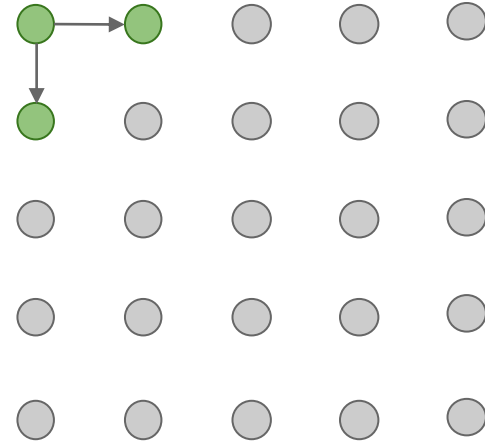

# PixelRNN [van der Oord et al. 2016]

Generate image pixels starting from corner

Dependency on previous pixels modeled using an RNN (LSTM)

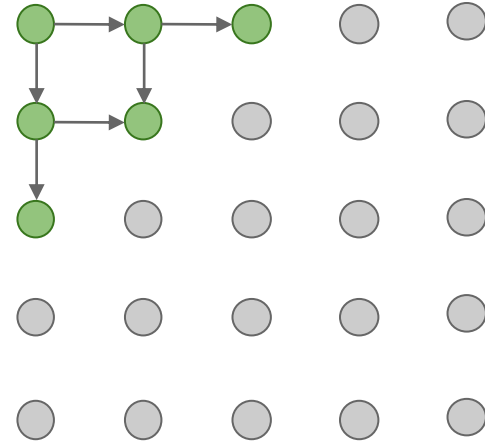

# PixelRNN [van der Oord et al. 2016]

Generate image pixels starting from corner

Dependency on previous pixels modeled using an RNN (LSTM)

Drawback: sequential generation is slow in both training and inference!

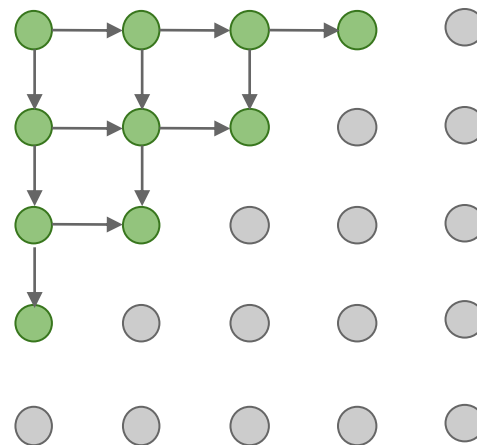

# PixelCNN *[van der Oord et al. 2016]*

Still generate image pixels starting from corner

Dependency on previous pixels now modeled using a CNN over context region (**masked convolution**)

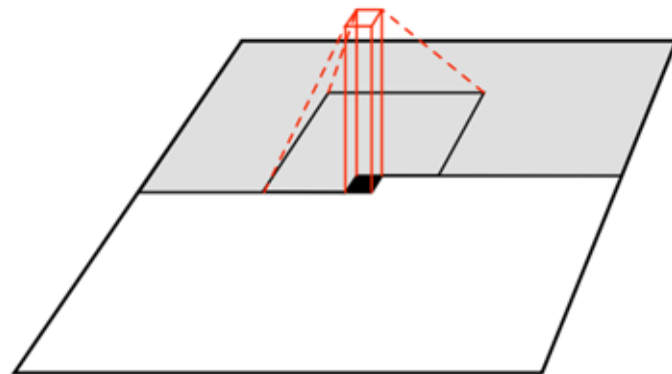

Figure copyright van der Oord et al., 2016. Reproduced with permission.

# PixelCNN *[van der Oord et al. 2016]*

Still generate image pixels starting from corner

Dependency on previous pixels now modeled using a CNN over context region (masked convolution)

Training is faster than PixelRNN  
(can parallelize convolutions since context region values known from training images)

Generation is still slow:  
For a 32x32 image, we need to do forward passes of the network 1024 times for a single image

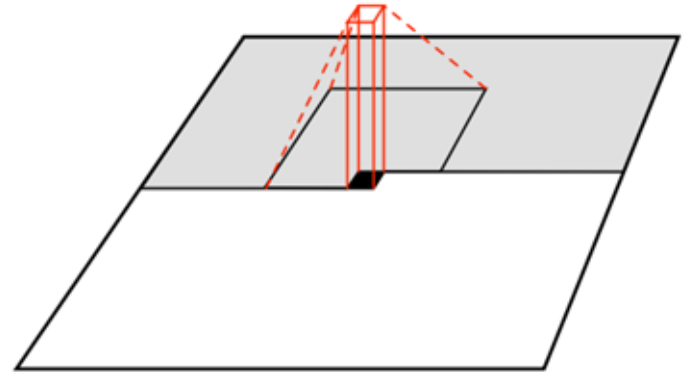

Figure copyright van der Oord et al., 2016. Reproduced with permission.

# Generation Samples



32x32 CIFAR-10



32x32 ImageNet

Figures copyright Aaron van der Oord et al., 2016. Reproduced with permission.

# PixelRNN and PixelCNN

## Pros:

- Can explicitly compute likelihood  $p(x)$
- Easy to optimize
- Good samples

## Con:

- Sequential generation => slow

## Improving PixelCNN performance

- Gated convolutional layers
- Short-cut connections
- Discretized logistic loss
- Multi-scale
- Training tricks
- Etc...

## See

- Van der Oord et al. NIPS 2016
- Salimans et al. 2017 (PixelCNN++)

# Taxonomy of Generative Models

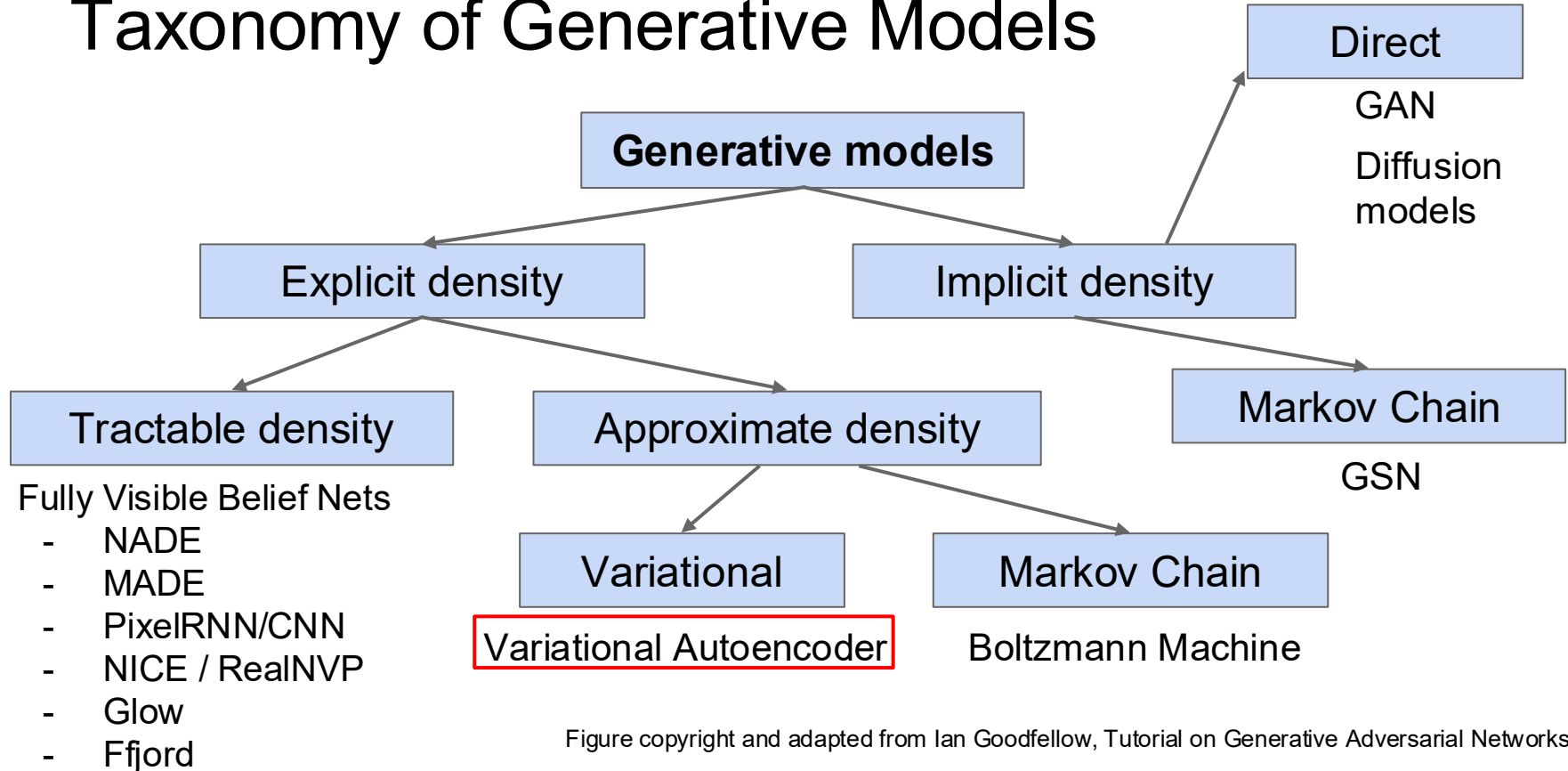

Figure copyright and adapted from Ian Goodfellow, Tutorial on Generative Adversarial Networks, 2017.

# Variational Autoencoders (VAE)

# So far...

PixelRNN/CNNs define tractable density function, optimize likelihood of training data:

$$p_{\theta}(x) = \prod_{i=1}^n p_{\theta}(x_i | x_1, \dots, x_{i-1})$$

# So far...

PixelRNN/CNNs define tractable density function, optimize likelihood of training data:

$$p_{\theta}(x) = \prod_{i=1}^n p_{\theta}(x_i | x_1, \dots, x_{i-1})$$

Variational Autoencoders (VAEs) define intractable density function with latent  $\mathbf{z}$ :

$$p_{\theta}(x) = \int p_{\theta}(z) p_{\theta}(x|z) dz$$

No dependencies among pixels, can generate all pixels at the same time!

Cannot optimize directly, derive and optimize lower bound on likelihood instead

# So far...

PixelRNN/CNNs define tractable density function, optimize likelihood of training data:

$$p_{\theta}(x) = \prod_{i=1}^n p_{\theta}(x_i | x_1, \dots, x_{i-1})$$

Variational Autoencoders (VAEs) define intractable density function with latent  $\mathbf{z}$ :

$$p_{\theta}(x) = \int p_{\theta}(z) p_{\theta}(x|z) dz$$

No dependencies among pixels, can generate all pixels at the same time!

Cannot optimize directly, derive and optimize lower bound on likelihood instead

Why latent  $\mathbf{z}$ ?

# Some background first: Autoencoders

Unsupervised approach for learning a lower-dimensional feature representation from unlabeled training data

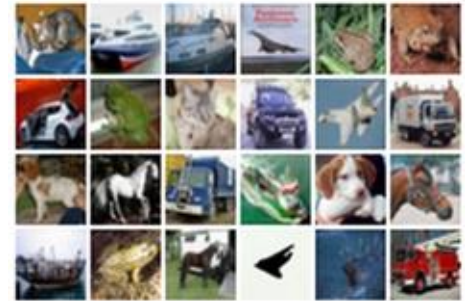
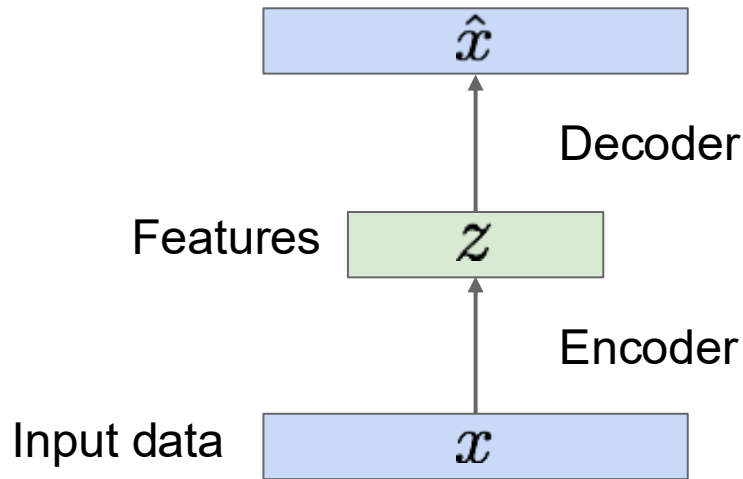

# Some background first: Autoencoders

Unsupervised approach for learning a lower-dimensional feature representation from unlabeled training data

$\mathbf{z}$  usually smaller than  $\mathbf{x}$   
(dimensionality reduction)

Q: Why dimensionality reduction?

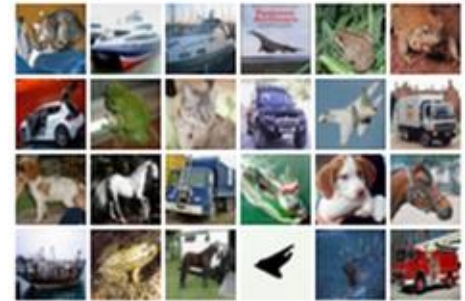
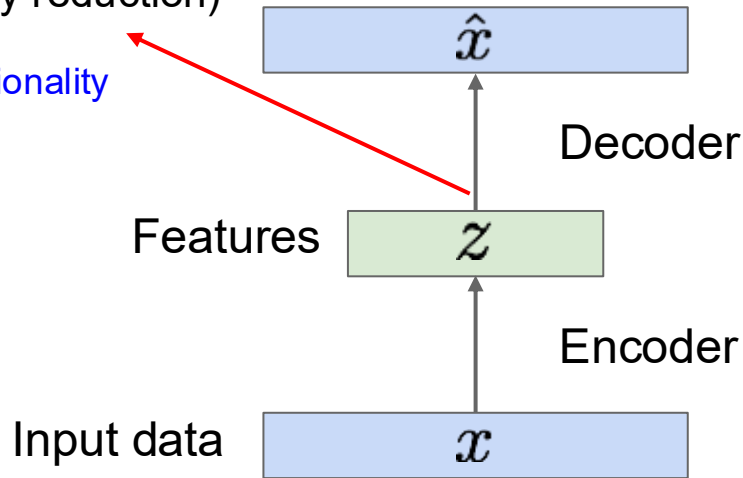



# Some background first: Autoencoders

How to learn this feature representation?

Train such that features can be used to reconstruct original data  
“Autoencoding” - encoding input itself

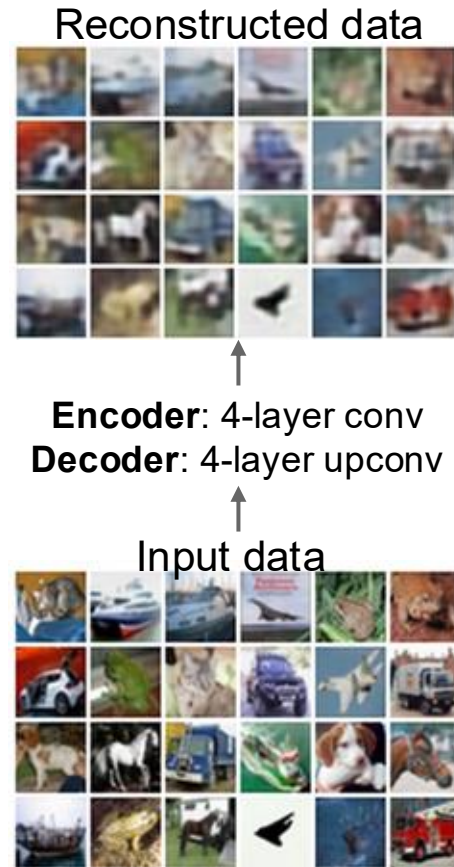
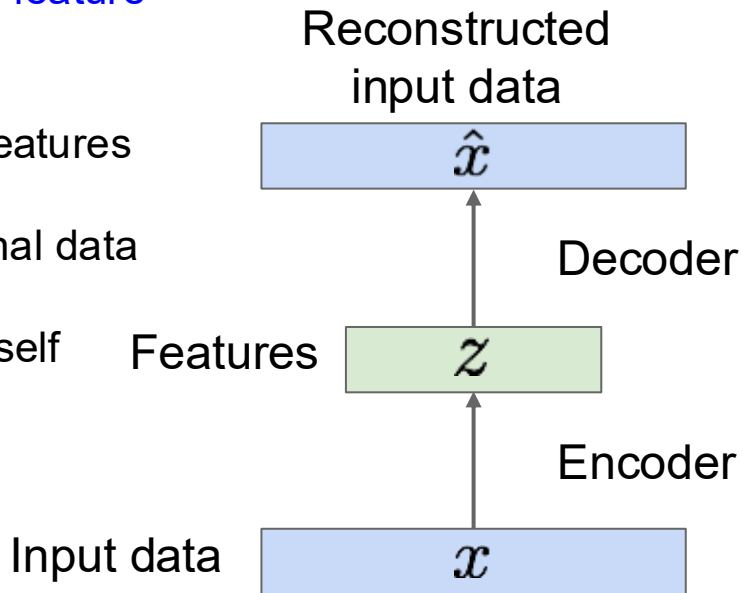

# Some background first: Autoencoders

Train such that features can be used to reconstruct original data

Doesn't use labels!

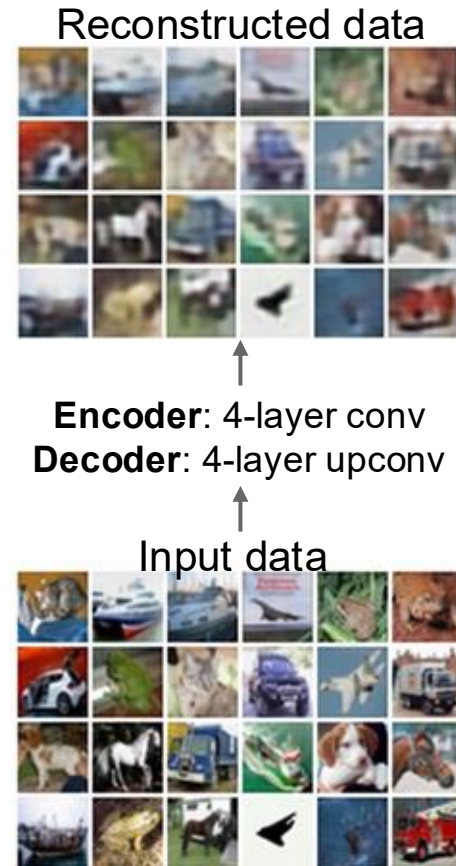
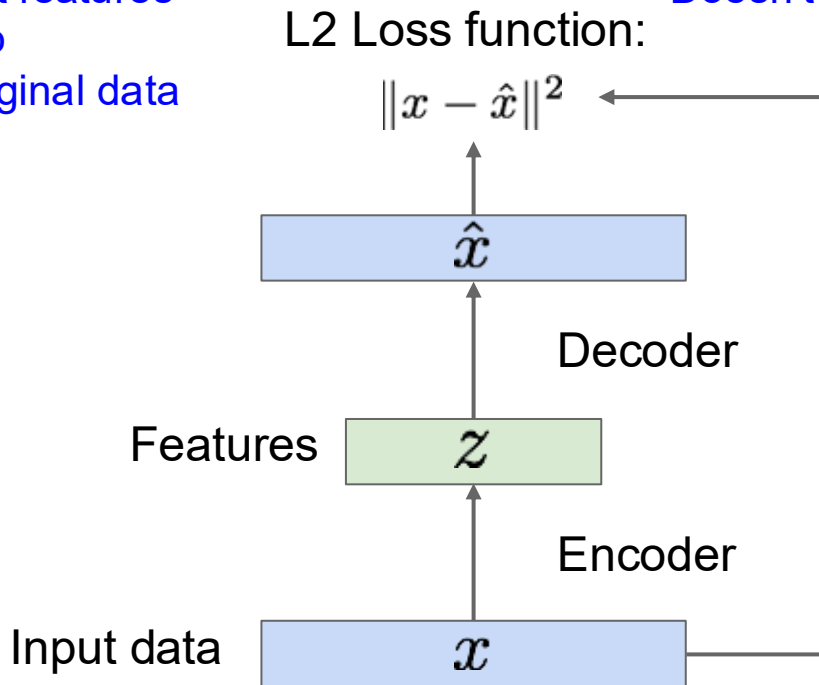

# Some background first: Autoencoders

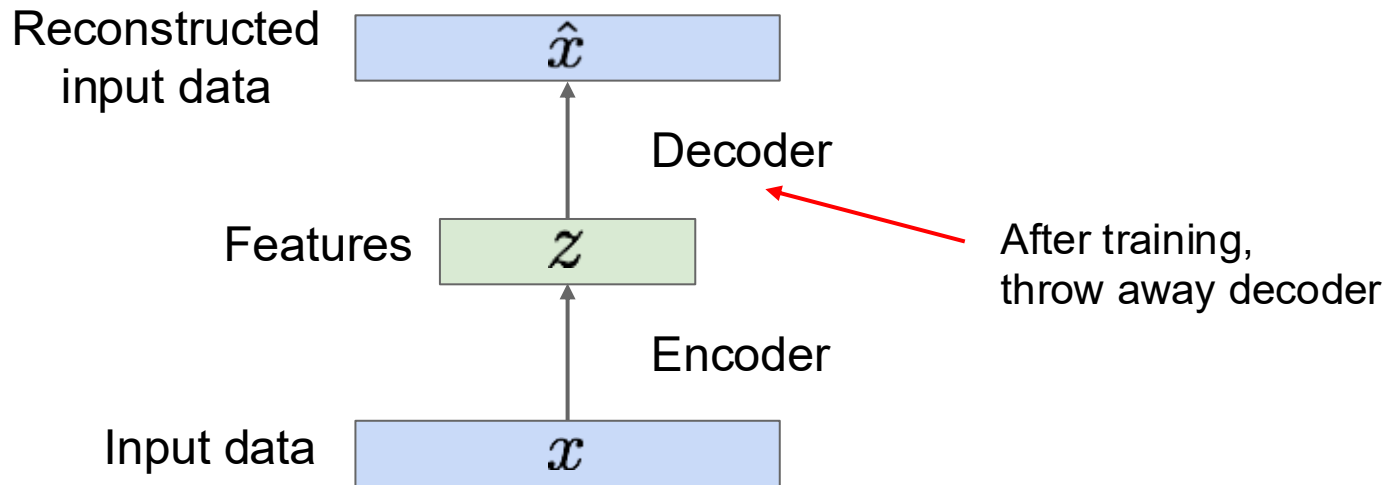

# Some background first: Autoencoders

Transfer from large, unlabeled dataset to small, labeled dataset.

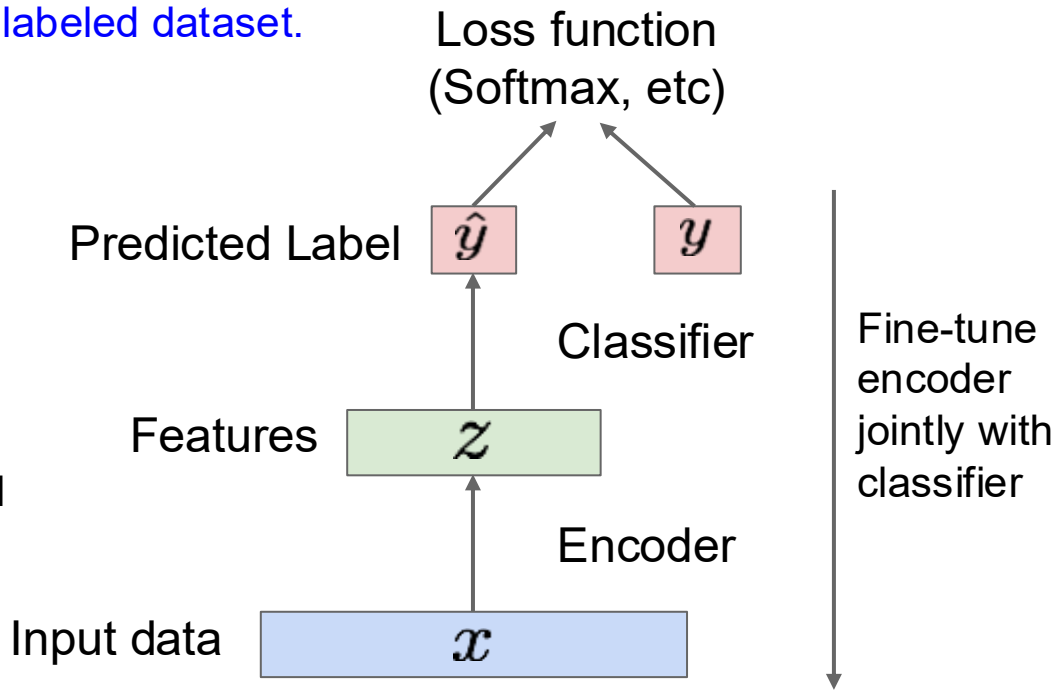

bird    plane  
dog    deer    truck

Train for final task (sometimes with small data)

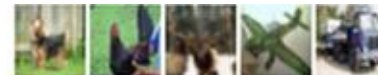

Encoder can be used to initialize a **supervised** model

# Some background first: Autoencoders

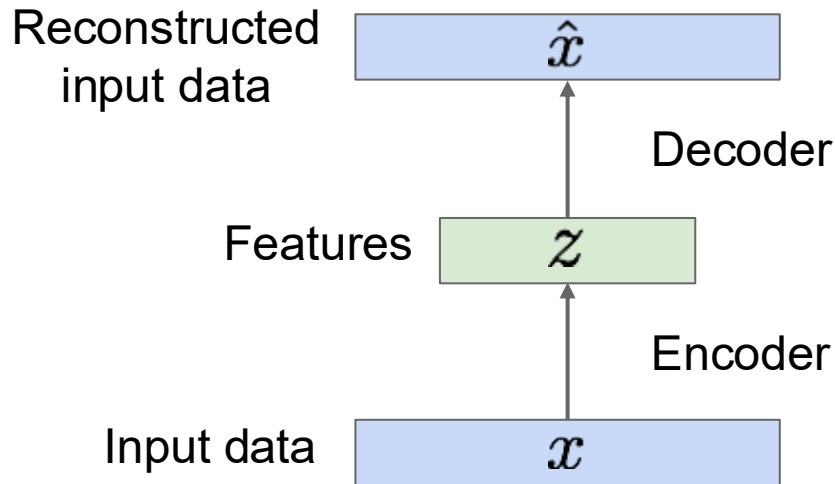

Autoencoders can reconstruct data, and can learn features to initialize a supervised model

Features capture factors of variation in training data.

But we can't generate new images from an autoencoder because we don't know the space of  $z$ .

How do we make autoencoder a **generative model**?

# Variational Autoencoders

Probabilistic spin on autoencoders - will let us sample from the model to generate data!

# Variational Autoencoders

Probabilistic spin on autoencoders - will let us sample from the model to generate data!

Assume training data  $\{x^{(i)}\}_{i=1}^N$  is generated from the distribution of unobserved (latent) representation  $\mathbf{z}$

Sample from  
true conditional

$$p_{\theta^*}(x | z^{(i)})$$

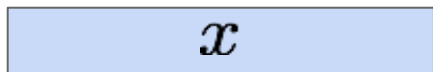

Sample from  
true prior

$$z^{(i)} \sim p_{\theta^*}(z)$$

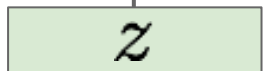

Kingma and Welling, "Auto-Encoding Variational Bayes", ICLR 2014

# Variational Autoencoders

Probabilistic spin on autoencoders - will let us sample from the model to generate data!

Assume training data  $\{x^{(i)}\}_{i=1}^N$  is generated from the distribution of unobserved (latent) representation  $\mathbf{z}$

Sample from  
true conditional

$$p_{\theta^*}(x | z^{(i)})$$

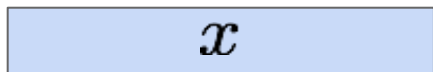

Sample from  
true prior

$$z^{(i)} \sim p_{\theta^*}(z)$$

**Intuition** (remember from autoencoders!):  
 $\mathbf{x}$  is an image,  $\mathbf{z}$  is latent factors used to  
generate  $\mathbf{x}$ : attributes, orientation, etc.

Kingma and Welling, "Auto-Encoding Variational Bayes", ICLR 2014

# Variational Autoencoders

We want to estimate the true parameters  $\theta^*$  of this generative model given training data  $x$ .

Sample from  
true conditional

$$p_{\theta^*}(x | z^{(i)})$$

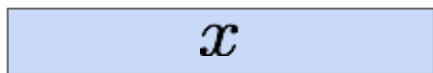

Sample from  
true prior

$$z^{(i)} \sim p_{\theta^*}(z)$$

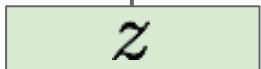

Kingma and Welling, "Auto-Encoding Variational Bayes", ICLR 2014

# Variational Autoencoders

We want to estimate the true parameters  $\theta^*$  of this generative model given training data  $x$ .

Sample from true conditional

$$p_{\theta^*}(x | z^{(i)})$$

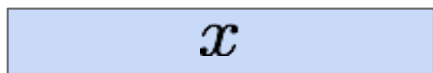

Sample from true prior

$$z^{(i)} \sim p_{\theta^*}(z)$$

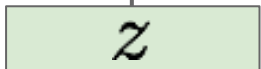

How should we represent this model?

Kingma and Welling, "Auto-Encoding Variational Bayes", ICLR 2014

# Variational Autoencoders

Sample from  
true conditional

$$p_{\theta^*}(x | z^{(i)})$$

Sample from  
true prior

$$z^{(i)} \sim p_{\theta^*}(z)$$

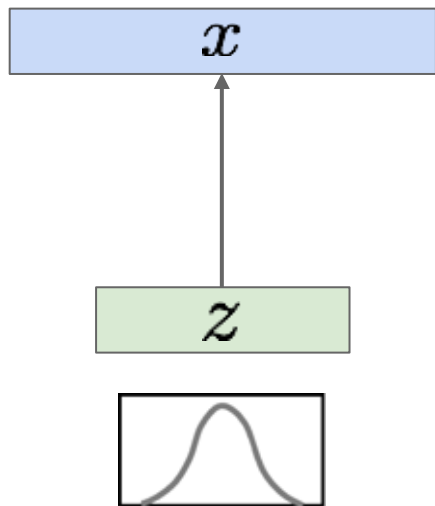

We want to estimate the true parameters  $\theta^*$  of this generative model given training data  $x$ .

How should we represent this model?

Choose prior  $p(z)$  to be simple, e.g. Gaussian. Reasonable for latent attributes, e.g. pose, how much smile.

Kingma and Welling, "Auto-Encoding Variational Bayes", ICLR 2014

# Variational Autoencoders



Sample from  
true conditional

$$p_{\theta^*}(x | z^{(i)})$$

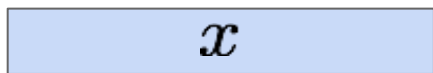

Decoder  
network

Sample from  
true prior

$$z^{(i)} \sim p_{\theta^*}(z)$$

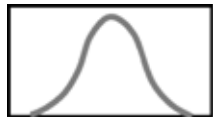
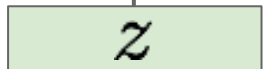

We want to estimate the true parameters  $\theta^*$  of this generative model given training data  $x$ .

How should we represent this model?

Choose prior  $p(z)$  to be simple, e.g. Gaussian. Reasonable for latent attributes, e.g. pose, how much smile.

Conditional  $p(x|z)$  is complex (generates image) => represent with neural network

Kingma and Welling, "Auto-Encoding Variational Bayes", ICLR 2014

# Variational Autoencoders

We want to estimate the true parameters  $\theta^*$  of this generative model given training data  $x$ .

Sample from true conditional

$$p_{\theta^*}(x | z^{(i)})$$

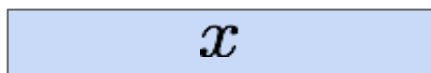

Decoder network

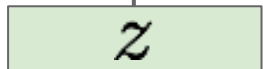

Sample from true prior

$$z^{(i)} \sim p_{\theta^*}(z)$$

How to train the model?

Kingma and Welling, "Auto-Encoding Variational Bayes", ICLR 2014

# Variational Autoencoders

Sample from  
true conditional

$$p_{\theta^*}(x | z^{(i)})$$

Sample from  
true prior

$$z^{(i)} \sim p_{\theta^*}(z)$$

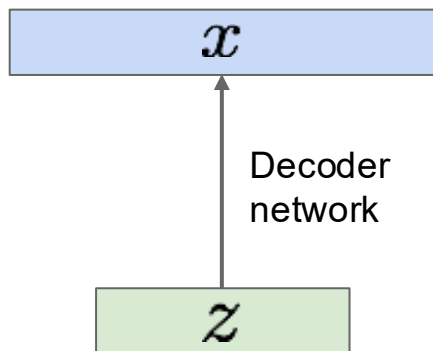

We want to estimate the true parameters  $\theta^*$  of this generative model given training data  $x$ .

How to train the model?

Learn model parameters to maximize likelihood of training data

$$p_{\theta}(x) = \int p_{\theta}(z)p_{\theta}(x|z)dz$$

Kingma and Welling, "Auto-Encoding Variational Bayes", ICLR 2014

# Variational Autoencoders

Sample from  
true conditional

$$p_{\theta^*}(x | z^{(i)})$$

Sample from  
true prior

$$z^{(i)} \sim p_{\theta^*}(z)$$

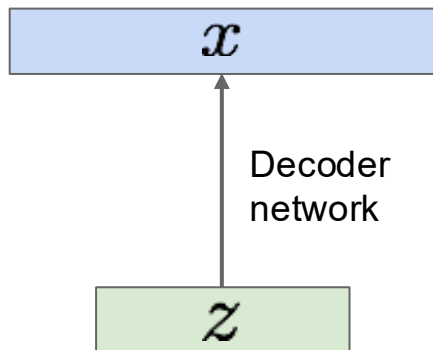

We want to estimate the true parameters  $\theta^*$  of this generative model given training data  $x$ .

How to train the model?

Learn model parameters to maximize likelihood of training data

$$p_{\theta}(x) = \int p_{\theta}(z)p_{\theta}(x|z)dz$$

Q: What is the problem with this?

Intractable!

Kingma and Welling, "Auto-Encoding Variational Bayes", ICLR 2014

# Variational Autoencoders: Intractability

Data likelihood:  $p_{\theta}(x) = \int p_{\theta}(z)p_{\theta}(x|z)dz$

Kingma and Welling, “Auto-Encoding Variational Bayes”, ICLR 2014

# Variational Autoencoders: Intractability

Data likelihood:  $p_{\theta}(x) = \int p_{\theta}(z) p_{\theta}(x|z) dz$

↑  
Simple Gaussian prior

Kingma and Welling, "Auto-Encoding Variational Bayes", ICLR 2014

# Variational Autoencoders: Intractability

Data likelihood:  $p_{\theta}(x) = \int p_{\theta}(z)p_{\theta}(x|z)dz$



Decoder neural network



Kingma and Welling, “Auto-Encoding Variational Bayes”, ICLR 2014

# Variational Autoencoders: Intractability

Data likelihood:  $p_{\theta}(x) = \int p_{\theta}(z) p_{\theta}(x|z) dz$

Intractable to compute  $p(x|z)$  for every  $z$ !

Kingma and Welling, "Auto-Encoding Variational Bayes", ICLR 2014

# Variational Autoencoders: Intractability

Data likelihood:  $p_{\theta}(x) = \int p_{\theta}(z) p_{\theta}(x|z) dz$

Intractable to compute  $p(x|z)$  for every  $z$ !



$$\log p(x) \approx \log \frac{1}{k} \sum_{i=1}^k p(x|z^{(i)}), \text{ where } z^{(i)} \sim p(z)$$

Monte Carlo estimation is too high variance

Kingma and Welling, "Auto-Encoding Variational Bayes", ICLR 2014

# Variational Autoencoders: Intractability

Data likelihood:  $p_{\theta}(x) = \int p_{\theta}(z) p_{\theta}(x|z) dz$

Posterior density:  $p_{\theta}(z|x) = p_{\theta}(x|z) p_{\theta}(z) / p_{\theta}(x)$



Intractable data likelihood

Kingma and Welling, "Auto-Encoding Variational Bayes", ICLR 2014

# Variational Autoencoders: Intractability

Data likelihood:  $p_{\theta}(x) = \int p_{\theta}(z)p_{\theta}(x|z)dz$

Posterior density also intractable:  $p_{\theta}(z|x) = p_{\theta}(x|z)p_{\theta}(z)/p_{\theta}(x)$

**Solution:** In addition to modeling  $p_{\theta}(x|z)$ , learn  $q_{\phi}(z|x)$  that approximates the true posterior  $p_{\theta}(z|x)$ .

Will see that the approximate posterior allows us to derive a lower bound on the data likelihood that is tractable, which we can optimize.

**Variational inference** is to approximate the unknown posterior distribution from only the observed data  $x$

Kingma and Welling, “Auto-Encoding Variational Bayes”, ICLR 2014

# Variational Autoencoders

$$\log p_{\theta}(x^{(i)}) = \mathbf{E}_{z \sim q_{\phi}(z|x^{(i)})} [\log p_{\theta}(x^{(i)})] \quad (p_{\theta}(x^{(i)}) \text{ Does not depend on } z)$$

# Variational Autoencoders

$$\log p_{\theta}(x^{(i)}) = \mathbf{E}_{z \sim q_{\phi}(z|x^{(i)})} [\log p_{\theta}(x^{(i)})] \quad (p_{\theta}(x^{(i)}) \text{ Does not depend on } z)$$

 Taking expectation wrt.  $z$   
(using encoder network) will  
come in handy later

# Variational Autoencoders

$$\begin{aligned}\log p_{\theta}(x^{(i)}) &= \mathbf{E}_{z \sim q_{\phi}(z|x^{(i)})} \left[ \log p_{\theta}(x^{(i)}) \right] && (p_{\theta}(x^{(i)})) \text{ Does not depend on } z \\ &= \mathbf{E}_z \left[ \log \frac{p_{\theta}(x^{(i)} | z)p_{\theta}(z)}{p_{\theta}(z | x^{(i)})} \right] && (\text{Bayes' Rule})\end{aligned}$$

# Variational Autoencoders

$$\begin{aligned}\log p_{\theta}(x^{(i)}) &= \mathbf{E}_{z \sim q_{\phi}(z|x^{(i)})} \left[ \log p_{\theta}(x^{(i)}) \right] && (p_{\theta}(x^{(i)}) \text{ Does not depend on } z) \\ &= \mathbf{E}_z \left[ \log \frac{p_{\theta}(x^{(i)} | z)p_{\theta}(z)}{p_{\theta}(z | x^{(i)})} \right] && (\text{Bayes' Rule}) \\ &= \mathbf{E}_z \left[ \log \frac{p_{\theta}(x^{(i)} | z)p_{\theta}(z)}{p_{\theta}(z | x^{(i)})} \frac{q_{\phi}(z | x^{(i)})}{q_{\phi}(z | x^{(i)})} \right] && (\text{Multiply by constant})\end{aligned}$$

# Variational Autoencoders

$$\begin{aligned}\log p_{\theta}(x^{(i)}) &= \mathbf{E}_{z \sim q_{\phi}(z|x^{(i)})} \left[ \log p_{\theta}(x^{(i)}) \right] && (p_{\theta}(x^{(i)}) \text{ Does not depend on } z) \\ &= \mathbf{E}_z \left[ \log \frac{p_{\theta}(x^{(i)} | z)p_{\theta}(z)}{p_{\theta}(z | x^{(i)})} \right] && (\text{Bayes' Rule}) \\ &= \mathbf{E}_z \left[ \log \frac{p_{\theta}(x^{(i)} | z)p_{\theta}(z)}{p_{\theta}(z | x^{(i)})} \frac{q_{\phi}(z | x^{(i)})}{q_{\phi}(z | x^{(i)})} \right] && (\text{Multiply by constant}) \\ &= \mathbf{E}_z \left[ \log p_{\theta}(x^{(i)} | z) \right] - \mathbf{E}_z \left[ \log \frac{q_{\phi}(z | x^{(i)})}{p_{\theta}(z)} \right] + \mathbf{E}_z \left[ \log \frac{q_{\phi}(z | x^{(i)})}{p_{\theta}(z | x^{(i)})} \right] && (\text{Logarithms})\end{aligned}$$

# Variational Autoencoders

$$\begin{aligned}\log p_{\theta}(x^{(i)}) &= \mathbf{E}_{z \sim q_{\phi}(z|x^{(i)})} \left[ \log p_{\theta}(x^{(i)}) \right] \quad (p_{\theta}(x^{(i)}) \text{ Does not depend on } z) \\ &= \mathbf{E}_z \left[ \log \frac{p_{\theta}(x^{(i)} | z) p_{\theta}(z)}{p_{\theta}(z | x^{(i)})} \right] \quad (\text{Bayes' Rule}) \\ &= \mathbf{E}_z \left[ \log \frac{p_{\theta}(x^{(i)} | z) p_{\theta}(z) q_{\phi}(z | x^{(i)})}{p_{\theta}(z | x^{(i)}) q_{\phi}(z | x^{(i)})} \right] \quad (\text{Multiply by constant}) \\ &= \mathbf{E}_z \left[ \log p_{\theta}(x^{(i)} | z) \right] - \mathbf{E}_z \left[ \log \frac{q_{\phi}(z | x^{(i)})}{p_{\theta}(z)} \right] + \mathbf{E}_z \left[ \log \frac{q_{\phi}(z | x^{(i)})}{p_{\theta}(z | x^{(i)})} \right] \quad (\text{Logarithms}) \\ &= \mathbf{E}_z \left[ \log p_{\theta}(x^{(i)} | z) \right] - D_{KL}(q_{\phi}(z | x^{(i)}) || p_{\theta}(z)) + D_{KL}(q_{\phi}(z | x^{(i)}) || p_{\theta}(z | x^{(i)}))\end{aligned}$$

←      ↗  
The expectation wrt.  $z$  (using  
encoder network) let us write  
nice KL terms

# Variational Autoencoders

$$\begin{aligned}\log p_{\theta}(x^{(i)}) &= \mathbf{E}_{z \sim q_{\phi}(z|x^{(i)})} \left[ \log p_{\theta}(x^{(i)}) \right] \quad (p_{\theta}(x^{(i)}) \text{ Does not depend on } z) \\ &= \mathbf{E}_z \left[ \log \frac{p_{\theta}(x^{(i)} | z) p_{\theta}(z)}{p_{\theta}(z | x^{(i)})} \right] \quad (\text{Bayes' Rule}) \\ &= \mathbf{E}_z \left[ \log \frac{p_{\theta}(x^{(i)} | z) p_{\theta}(z) q_{\phi}(z | x^{(i)})}{p_{\theta}(z | x^{(i)}) q_{\phi}(z | x^{(i)})} \right] \quad (\text{Multiply by constant}) \\ &= \mathbf{E}_z \left[ \log p_{\theta}(x^{(i)} | z) \right] - \mathbf{E}_z \left[ \log \frac{q_{\phi}(z | x^{(i)})}{p_{\theta}(z)} \right] + \mathbf{E}_z \left[ \log \frac{q_{\phi}(z | x^{(i)})}{p_{\theta}(z | x^{(i)})} \right] \quad (\text{Logarithms}) \\ &= \mathbf{E}_z \left[ \log p_{\theta}(x^{(i)} | z) \right] - D_{KL}(q_{\phi}(z | x^{(i)}) || p_{\theta}(z)) + D_{KL}(q_{\phi}(z | x^{(i)}) || p_{\theta}(z | x^{(i)}))\end{aligned}$$

↑  
Decoder network gives  $p_{\theta}(x|z)$ , can compute estimate of this term through sampling (need some trick to differentiate through sampling).

↑  
This KL term (between Gaussians for encoder and  $z$  prior) has nice closed-form solution!

↑  
 $p_{\theta}(z|x)$  intractable (saw earlier), can't compute this KL term :( But we know KL divergence always  $\geq 0$ .

# Variational Autoencoders

$$\log p_{\theta}(x^{(i)}) = \mathbf{E}_{z \sim q_{\phi}(z|x^{(i)})} \left[ \log p_{\theta}(x^{(i)}) \right] \quad (p_{\theta}(x^{(i)}) \text{ Does not depend on } z)$$

We want to maximize the data likelihood

$$= \mathbf{E}_z \left[ \log \frac{p_{\theta}(x^{(i)} | z) p_{\theta}(z)}{p_{\theta}(z | x^{(i)})} \right] \quad (\text{Bayes' Rule})$$

$$= \mathbf{E}_z \left[ \log \frac{p_{\theta}(x^{(i)} | z) p_{\theta}(z) q_{\phi}(z | x^{(i)})}{p_{\theta}(z | x^{(i)}) q_{\phi}(z | x^{(i)})} \right] \quad (\text{Multiply by constant})$$

$$= \mathbf{E}_z \left[ \log p_{\theta}(x^{(i)} | z) \right] - \mathbf{E}_z \left[ \log \frac{q_{\phi}(z | x^{(i)})}{p_{\theta}(z)} \right] + \mathbf{E}_z \left[ \log \frac{q_{\phi}(z | x^{(i)})}{p_{\theta}(z | x^{(i)})} \right] \quad (\text{Logarithms})$$

$$= \mathbf{E}_z \left[ \log p_{\theta}(x^{(i)} | z) \right] - D_{KL}(q_{\phi}(z | x^{(i)}) || p_{\theta}(z)) + D_{KL}(q_{\phi}(z | x^{(i)}) || p_{\theta}(z | x^{(i)}))$$

Decoder network gives  $p_{\theta}(x|z)$ , can compute estimate of this term through sampling.

This KL term (between Gaussians for encoder and z prior) has nice closed-form solution!

$p_{\theta}(z|x)$  intractable (saw earlier), can't compute this KL term :( But we know KL divergence always  $\geq 0$ .

# Variational Autoencoders

We want to maximize the data likelihood

$$\begin{aligned}\log p_{\theta}(x^{(i)}) &= \mathbf{E}_{z \sim q_{\phi}(z|x^{(i)})} \left[ \log p_{\theta}(x^{(i)}) \right] \quad (p_{\theta}(x^{(i)}) \text{ Does not depend on } z) \\ &= \mathbf{E}_z \left[ \log \frac{p_{\theta}(x^{(i)} | z) p_{\theta}(z)}{p_{\theta}(z | x^{(i)})} \right] \quad (\text{Bayes' Rule}) \\ &= \mathbf{E}_z \left[ \log \frac{p_{\theta}(x^{(i)} | z) p_{\theta}(z) q_{\phi}(z | x^{(i)})}{p_{\theta}(z | x^{(i)}) q_{\phi}(z | x^{(i)})} \right] \quad (\text{Multiply by constant}) \\ &= \mathbf{E}_z \left[ \log p_{\theta}(x^{(i)} | z) \right] - \mathbf{E}_z \left[ \log \frac{q_{\phi}(z | x^{(i)})}{p_{\theta}(z)} \right] + \mathbf{E}_z \left[ \log \frac{q_{\phi}(z | x^{(i)})}{p_{\theta}(z | x^{(i)})} \right] \quad (\text{Logarithms}) \\ &= \underbrace{\mathbf{E}_z \left[ \log p_{\theta}(x^{(i)} | z) \right] - D_{KL}(q_{\phi}(z | x^{(i)}) || p_{\theta}(z))}_{\mathcal{L}(x^{(i)}, \theta, \phi)} + \underbrace{D_{KL}(q_{\phi}(z | x^{(i)}) || p_{\theta}(z | x^{(i)}))}_{\geq 0}\end{aligned}$$

**Tractable lower bound** which we can take gradient of and optimize! ( $p_{\theta}(x|z)$  differentiable, KL term differentiable)

# Variational Autoencoders

$$\log p_{\theta}(x^{(i)}) = \mathbf{E}_{z \sim q_{\phi}(z|x^{(i)})} \left[ \log p_{\theta}(x^{(i)}) \right] \quad (p_{\theta}(x^{(i)}) \text{ Does not depend on } z)$$

$$= \mathbf{E}_z \left[ \log \frac{p_{\theta}(x^{(i)} | z) p_{\theta}(z)}{p_{\theta}(z | x^{(i)})} \right] \quad (\text{Bayes' Rule})$$

Decoder:  
reconstruct  
the input data

$$= \mathbf{E}_z \left[ \log \frac{p_{\theta}(x^{(i)} | z) p_{\theta}(z) q_{\phi}(z | x^{(i)})}{p_{\theta}(z | x^{(i)}) q_{\phi}(z | x^{(i)})} \right] \quad (\text{Multiply by constant})$$

Encoder:  
make approximate  
posterior distribution  
close to prior

$$= \mathbf{E}_z \left[ \log p_{\theta}(x^{(i)} | z) \right] - \mathbf{E}_z \left[ \log \frac{q_{\phi}(z | x^{(i)})}{p_{\theta}(z)} \right] + \mathbf{E}_z \left[ \log \frac{q_{\phi}(z | x^{(i)})}{p_{\theta}(z | x^{(i)})} \right] \quad (\text{Logarithms})$$

$$= \underbrace{\mathbf{E}_z \left[ \log p_{\theta}(x^{(i)} | z) \right] - D_{KL}(q_{\phi}(z | x^{(i)}) || p_{\theta}(z))}_{\mathcal{L}(x^{(i)}, \theta, \phi)} + \underbrace{D_{KL}(q_{\phi}(z | x^{(i)}) || p_{\theta}(z | x^{(i)}))}_{\geq 0}$$

**Tractable lower bound** which we can take gradient of and optimize! ( $p_{\theta}(x|z)$  differentiable, KL term differentiable)

# Variational Autoencoders

Putting it all together: maximizing the likelihood lower bound

$$\underbrace{\mathbf{E}_z \left[ \log p_\theta(x^{(i)} | z) \right] - D_{KL}(q_\phi(z | x^{(i)}) || p_\theta(z))}_{\mathcal{L}(x^{(i)}, \theta, \phi)}$$

# Variational Autoencoders

Putting it all together: maximizing the likelihood lower bound

$$\underbrace{\mathbb{E}_z \left[ \log p_\theta(x^{(i)} | z) \right] - D_{KL}(q_\phi(z | x^{(i)}) || p_\theta(z))}_{\mathcal{L}(x^{(i)}, \theta, \phi)}$$

Let's look at computing the KL divergence between the estimated posterior and the prior given some data

Input Data

$x$

# Variational Autoencoders

Putting it all together: maximizing the likelihood lower bound

$$\underbrace{\mathbb{E}_z \left[ \log p_\theta(x^{(i)} | z) \right]}_{\mathcal{L}(x^{(i)}, \theta, \phi)} - D_{KL}(q_\phi(z | x^{(i)}) || p_\theta(z))$$

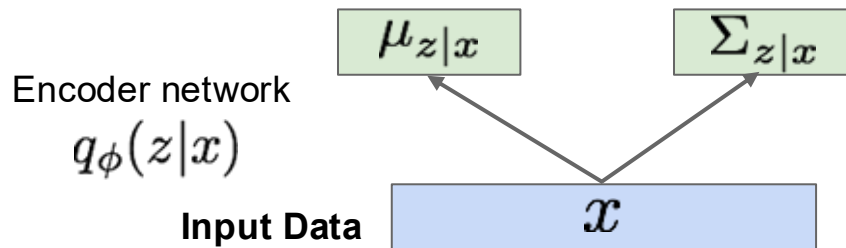

# Variational Autoencoders

Putting it all together: maximizing the likelihood lower bound

$$\underbrace{\mathbb{E}_z [\log p_\theta(x^{(i)} | z)] - D_{KL}(q_\phi(z | x^{(i)}) || p_\theta(z))}_{\mathcal{L}(x^{(i)}, \theta, \phi)}$$

$$D_{KL}(\mathcal{N}(\mu_{z|x}, \Sigma_{z|x}) || \mathcal{N}(0, I))$$

Have analytical solution

Make approximate posterior distribution close to prior

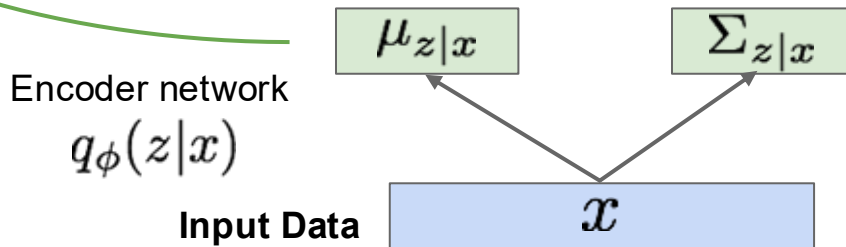

# Variational Autoencoders

Putting it all together: maximizing the likelihood lower bound

$$\underbrace{\mathbb{E}_z \left[ \log p_\theta(x^{(i)} | z) \right] - D_{KL}(q_\phi(z | x^{(i)}) || p_\theta(z))}_{\mathcal{L}(x^{(i)}, \theta, \phi)}$$

Make approximate posterior distribution close to prior

Encoder network

$$q_\phi(z|x)$$

Input Data

Not part of the computation graph!

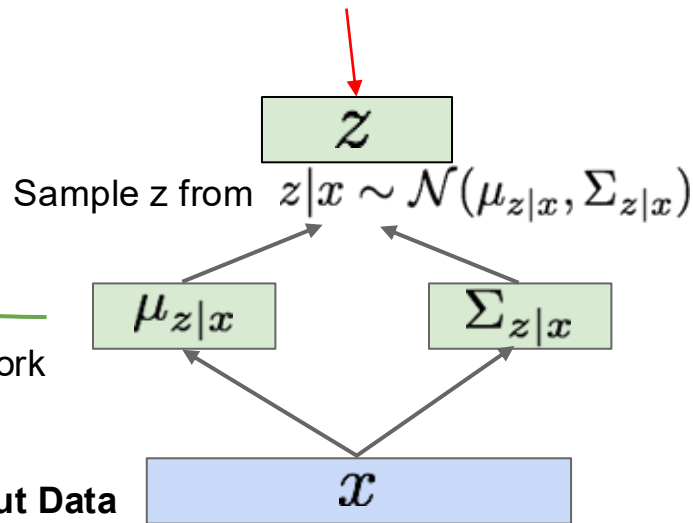

# Variational Autoencoders

Putting it all together: maximizing the likelihood lower bound

$$\underbrace{\mathbb{E}_z \left[ \log p_\theta(x^{(i)} | z) \right] - D_{KL}(q_\phi(z | x^{(i)}) || p_\theta(z))}_{\mathcal{L}(x^{(i)}, \theta, \phi)}$$

Reparameterization trick to make sampling differentiable:

$$\text{Sample } \epsilon \sim \mathcal{N}(0, I)$$

$$z = \mu_{z|x} + \epsilon \sigma_{z|x}$$

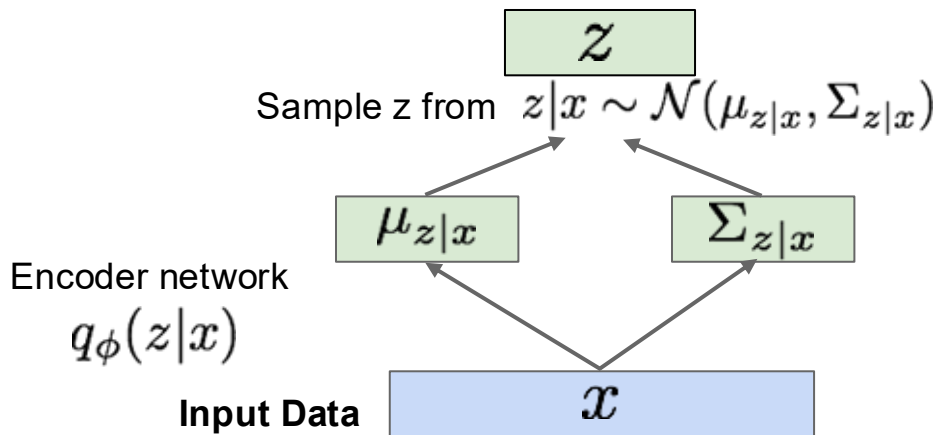

# Variational Autoencoders

Putting it all together: maximizing the likelihood lower bound

$$\underbrace{\mathbb{E}_z [\log p_\theta(x^{(i)} | z)] - D_{KL}(q_\phi(z | x^{(i)}) || p_\theta(z))}_{\mathcal{L}(x^{(i)}, \theta, \phi)}$$

Reparameterization trick to make sampling differentiable:

Sample  $\epsilon \sim \mathcal{N}(0, I)$

$$z = \mu_{z|x} + \epsilon \sigma_{z|x}$$

Input to the graph

Part of computation graph

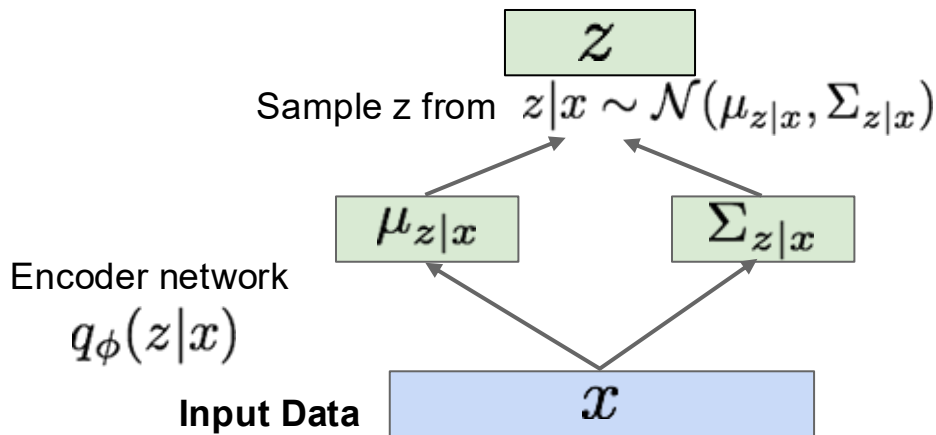

# Variational Autoencoders

Putting it all together: maximizing the likelihood lower bound

$$\underbrace{\mathbb{E}_z \left[ \log p_\theta(x^{(i)} | z) \right] - D_{KL}(q_\phi(z | x^{(i)}) || p_\theta(z))}_{\mathcal{L}(x^{(i)}, \theta, \phi)}$$

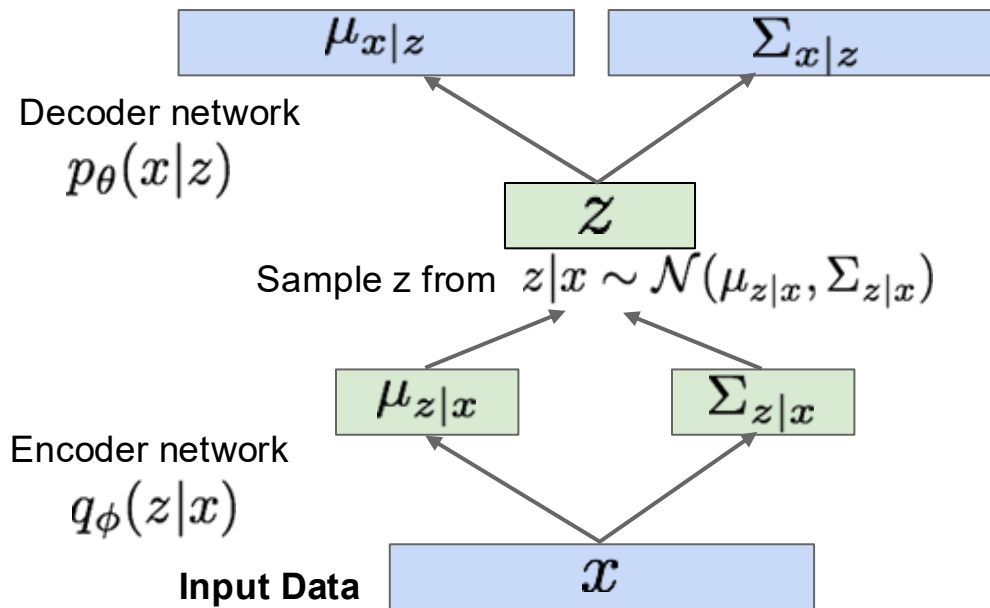

# Variational Autoencoders

Putting it all together: maximizing the likelihood lower bound

$$\underbrace{\mathbb{E}_z \left[ \log p_\theta(x^{(i)} | z) \right]}_{\mathcal{L}(x^{(i)}, \theta, \phi)} - D_{KL}(q_\phi(z | x^{(i)}) || p_\theta(z))$$

Maximize likelihood of original input being reconstructed

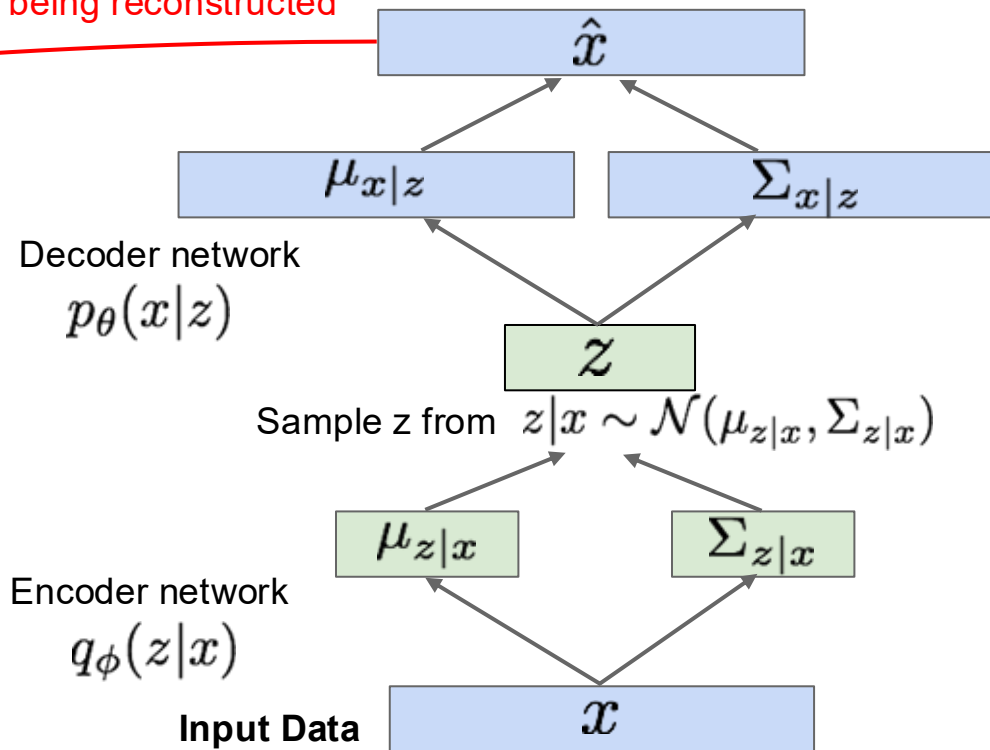

# Variational Autoencoders

Putting it all together: maximizing the likelihood lower bound

$$\mathbb{E}_z \left[ \log p_\theta(x^{(i)} | z) \right] - D_{KL}(q_\phi(z | x^{(i)}) || p_\theta(z))$$

$\mathcal{L}(x^{(i)}, \theta, \phi)$

For every minibatch of input data: compute this forward pass, and then backprop!

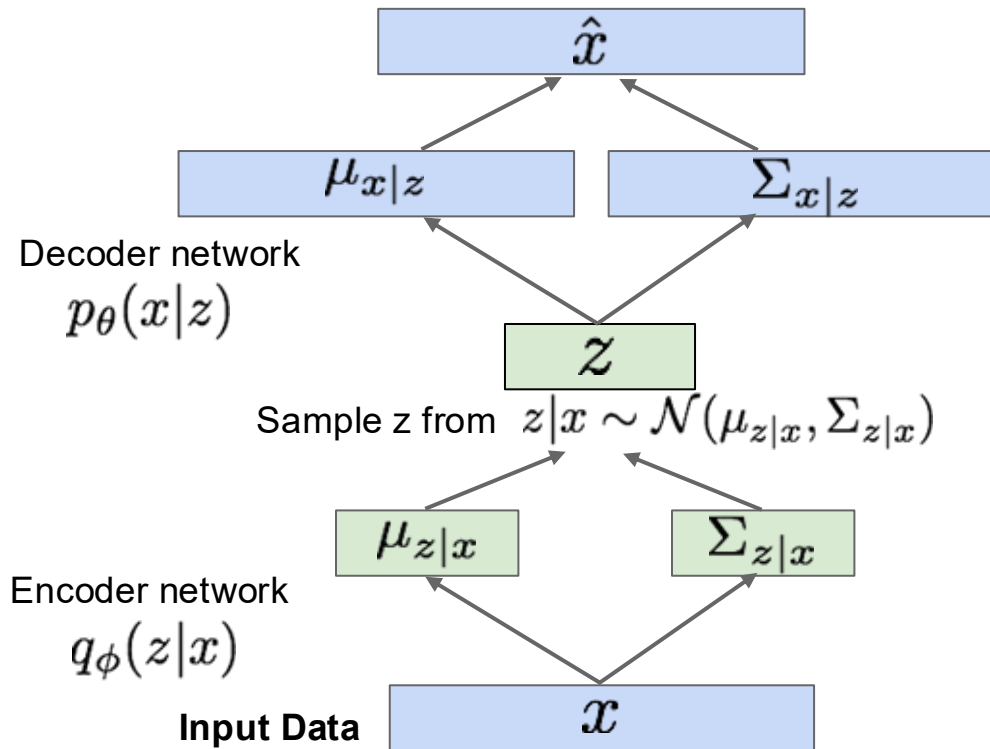

# Variational Autoencoders: Generating Data!

Our assumption about data generation process

Sample from true conditional

$$p_{\theta^*}(x | z^{(i)})$$

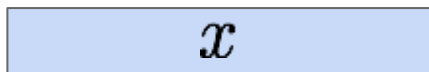

Sample from true prior

$$z^{(i)} \sim p_{\theta^*}(z)$$

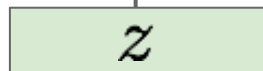

Decoder network



Kingma and Welling, "Auto-Encoding Variational Bayes", ICLR 2014

# Variational Autoencoders: Generating Data!

Our assumption about data generation process

Sample from true conditional

$$p_{\theta^*}(x | z^{(i)})$$

Sample from true prior

$$z^{(i)} \sim p_{\theta^*}(z)$$

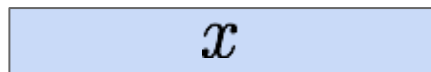

Decoder network

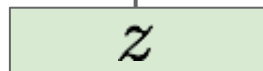

Now given a trained VAE:  
use decoder network & sample z from prior!

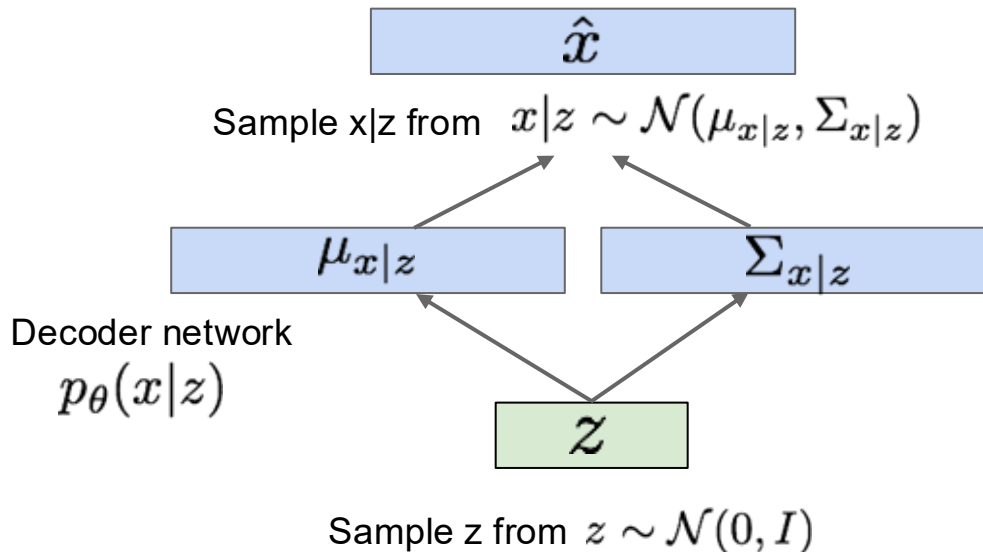

Kingma and Welling, "Auto-Encoding Variational Bayes", ICLR 2014

# Variational Autoencoders: Generating Data!

Use decoder network. Now sample  $z$  from prior!

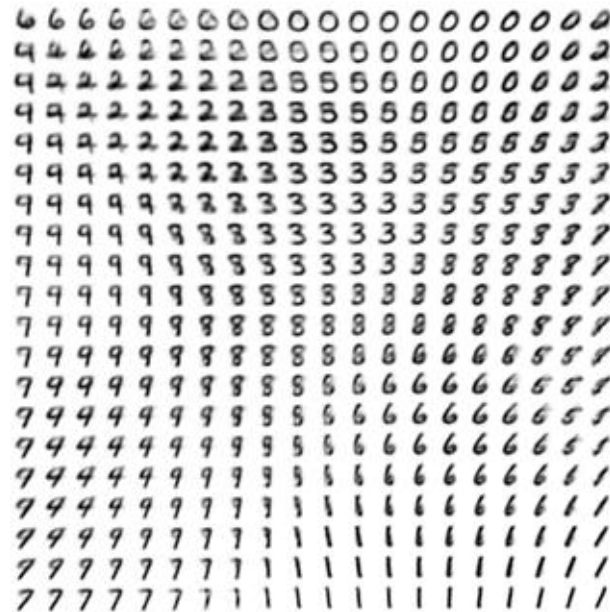
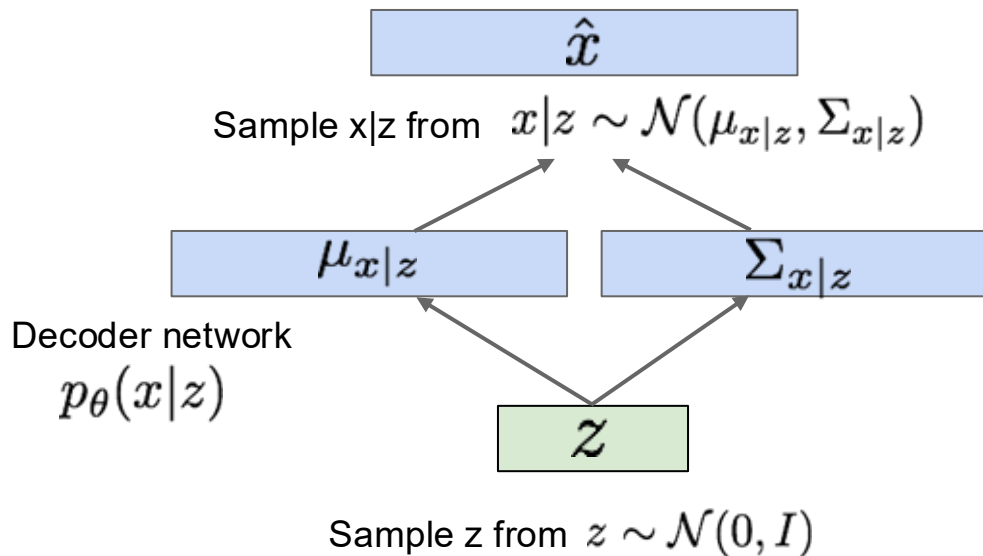

Kingma and Welling, "Auto-Encoding Variational Bayes", ICLR 2014

# Variational Autoencoders: Generating Data!

Use decoder network. Now sample  $z$  from prior!

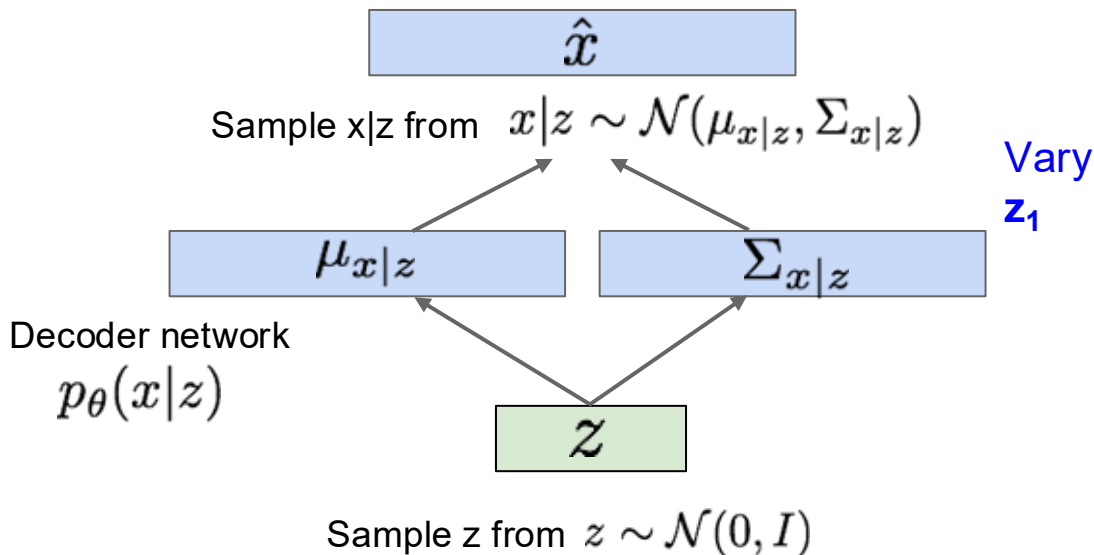

Data manifold for 2-d  $z$

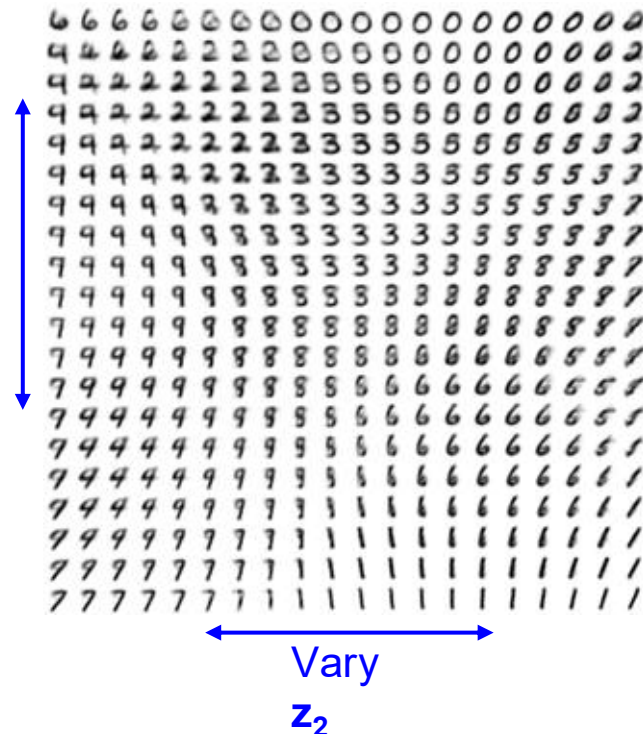

Kingma and Welling, "Auto-Encoding Variational Bayes", ICLR 2014

# Variational Autoencoders: Generating Data!

Diagonal prior on  $\mathbf{z}$   
=> independent  
latent variables

Different  
dimensions of  $\mathbf{z}$   
encode  
interpretable factors  
of variation

Degree of smile

Vary  
 $z_1$



Vary  
 $z_2$

Head pose

Kingma and Welling, "Auto-Encoding Variational Bayes", ICLR 2014

# Variational Autoencoders: Generating Data!

Diagonal prior on  $\mathbf{z}$   
=> independent  
latent variables

Different  
dimensions of  $\mathbf{z}$   
encode  
interpretable factors  
of variation

Also good feature representation that  
can be computed using  $q_\phi(\mathbf{z}|\mathbf{x})!$

Degree of smile

Vary  
 $z_1$



Vary  
 $z_2$

Head pose

Kingma and Welling, "Auto-Encoding Variational Bayes", ICLR 2014

# Variational Autoencoders: Generating Data!



32x32 CIFAR-10



Labeled Faces in the Wild

Figures copyright (L) Dirk Kingma et al. 2016; (R) Anders Larsen et al. 2017. Reproduced with permission.

# Variational Autoencoders

Probabilistic spin to traditional autoencoders => allows generating data  
Defines an intractable density => derive and optimize a (variational) lower bound

## Pros:

- Principled approach to generative models
- Interpretable latent space.
- Allows inference of  $q(z|x)$ , can be useful feature representation for other tasks

## Cons:

- Maximizes lower bound of likelihood: okay, but not as good evaluation as PixelRNN/PixelCNN
- Samples blurrier and lower quality compared to state-of-the-art (GANs)

## Active areas of research:

- More flexible approximations, e.g. richer approximate posterior instead of diagonal Gaussian, e.g., Gaussian Mixture Models (GMMs), Categorical Distributions.
- Learning disentangled representations.

# Taxonomy of Generative Models

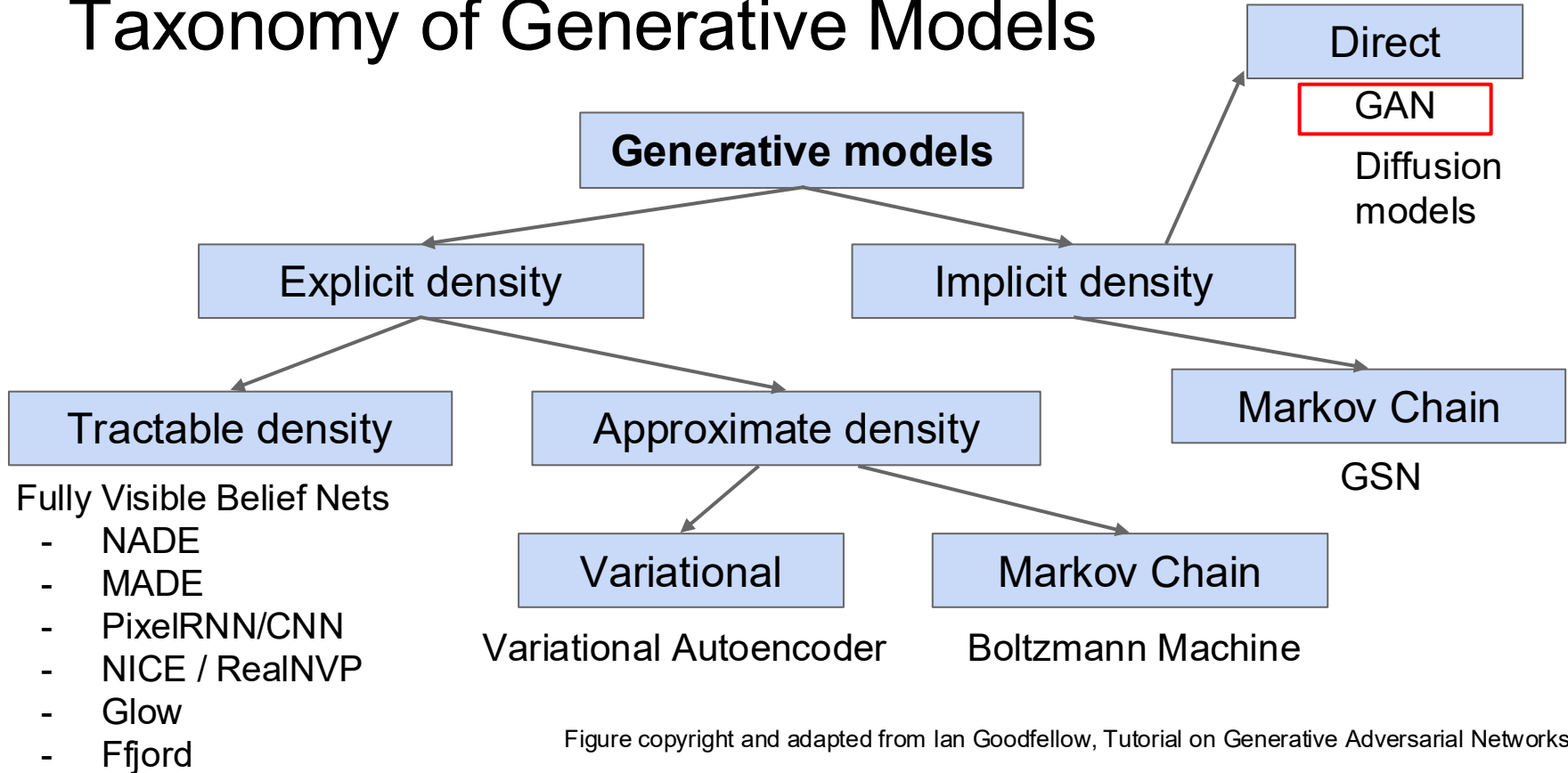

Figure copyright and adapted from Ian Goodfellow, Tutorial on Generative Adversarial Networks, 2017.

# Generative Adversarial Networks (GANs)

# So far...

PixelRNN/CNNs define tractable density function, optimize likelihood of training data:

$$p_{\theta}(x) = \prod_{i=1}^n p_{\theta}(x_i | x_1, \dots, x_{i-1})$$

VAEs define intractable density function with latent  $\mathbf{z}$ :

$$p_{\theta}(x) = \int p_{\theta}(z) p_{\theta}(x|z) dz$$

Cannot optimize directly, derive and optimize lower bound on likelihood instead

# So far...

PixelRNN/CNNs define tractable density function, optimize likelihood of training data:

$$p_{\theta}(x) = \prod_{i=1}^n p_{\theta}(x_i | x_1, \dots, x_{i-1})$$

VAEs define intractable density function with latent  $\mathbf{z}$ :

$$p_{\theta}(x) = \int p_{\theta}(z) p_{\theta}(x|z) dz$$

Cannot optimize directly, derive and optimize lower bound on likelihood instead

What if we give up on explicitly modeling density, and just want ability to sample?

# So far...

PixelRNN/CNNs define tractable density function, optimize likelihood of training data:

$$p_{\theta}(x) = \prod_{i=1}^n p_{\theta}(x_i | x_1, \dots, x_{i-1})$$

VAEs define intractable density function with latent  $\mathbf{z}$ :

$$p_{\theta}(x) = \int p_{\theta}(z) p_{\theta}(x|z) dz$$

Cannot optimize directly, derive and optimize lower bound on likelihood instead

What if we give up on explicitly modeling density, and just want ability to sample?

GANs: not modeling any explicit density function!

# Generative Adversarial Networks

Ian Goodfellow et al., “Generative Adversarial Nets”, NIPS 2014

Problem: Want to sample from complex, high-dimensional training distribution. No direct way to do this!

Solution: Sample from a simple distribution we can easily sample from, e.g. random noise. Learn transformation to training distribution.

# Generative Adversarial Networks

Ian Goodfellow et al., "Generative Adversarial Nets", NIPS 2014

Problem: Want to sample from complex, high-dimensional training distribution. No direct way to do this!

Solution: Sample from a simple distribution we can easily sample from, e.g. random noise. Learn transformation to training distribution.

Output: Sample from training distribution



Generator Network

Input: Random noise

z

# Generative Adversarial Networks

Ian Goodfellow et al., "Generative Adversarial Nets", NIPS 2014

Problem: Want to sample from complex, high-dimensional training distribution. No direct way to do this!

Solution: Sample from a simple distribution we can easily sample from, e.g. random noise. Learn transformation to training distribution.

But we don't know which sample  $z$  maps to which training image -> can't learn by reconstructing training images

Output: Sample from training distribution

Input: Random noise

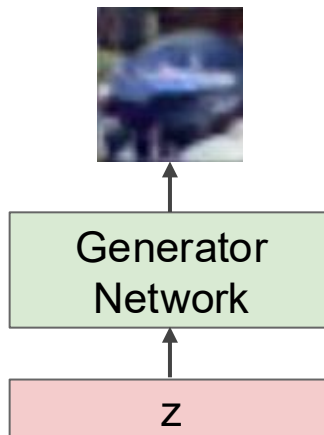

# Generative Adversarial Networks

Ian Goodfellow et al., "Generative Adversarial Nets", NIPS 2014

Problem: Want to sample from complex, high-dimensional training distribution. No direct way to do this!

Solution: Sample from a simple distribution we can easily sample from, e.g. random noise. Learn transformation to training distribution.

But we don't know which sample  $z$  maps to which training image -> can't learn by reconstructing training images

Output: Sample from training distribution



**Objective:** generated images should look "real"

Input: Random noise

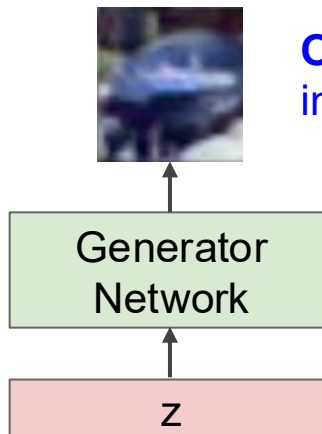

# Generative Adversarial Networks

Ian Goodfellow et al., "Generative Adversarial Nets", NIPS 2014

Problem: Want to sample from complex, high-dimensional training distribution. No direct way to do this!

Solution: Sample from a simple distribution we can easily sample from, e.g. random noise. Learn transformation to training distribution.

But we don't know which sample  $z$  maps to which training image -> can't learn by reconstructing training images

Solution: Use a discriminator network to tell whether the generate image is within data distribution ("real") or not

Output: Sample from training distribution

Input: Random noise

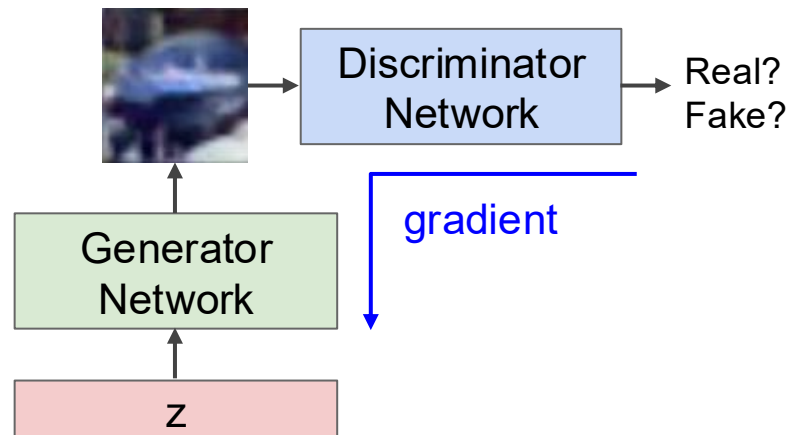

# Training GANs: Two-player game

Ian Goodfellow et al., “Generative Adversarial Nets”, NIPS 2014

**Discriminator network:** try to distinguish between real and fake images

**Generator network:** try to fool the discriminator by generating real-looking images

# Training GANs: Two-player game

Ian Goodfellow et al., "Generative Adversarial Nets", NIPS 2014

**Discriminator network:** try to distinguish between real and fake images

**Generator network:** try to fool the discriminator by generating real-looking images

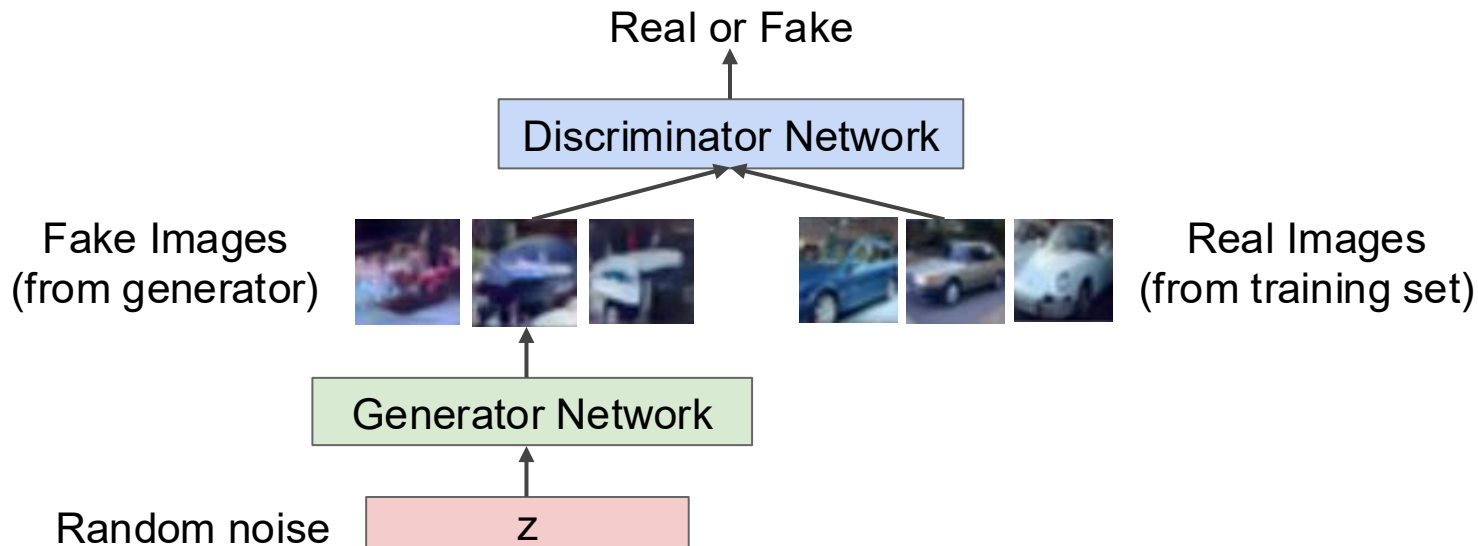

Fake and real images copyright Emily Denton et al. 2015. Reproduced with permission.

# Training GANs: Two-player game

Ian Goodfellow et al., "Generative Adversarial Nets", NIPS 2014

**Discriminator network:** try to distinguish between real and fake images

**Generator network:** try to fool the discriminator by generating real-looking images

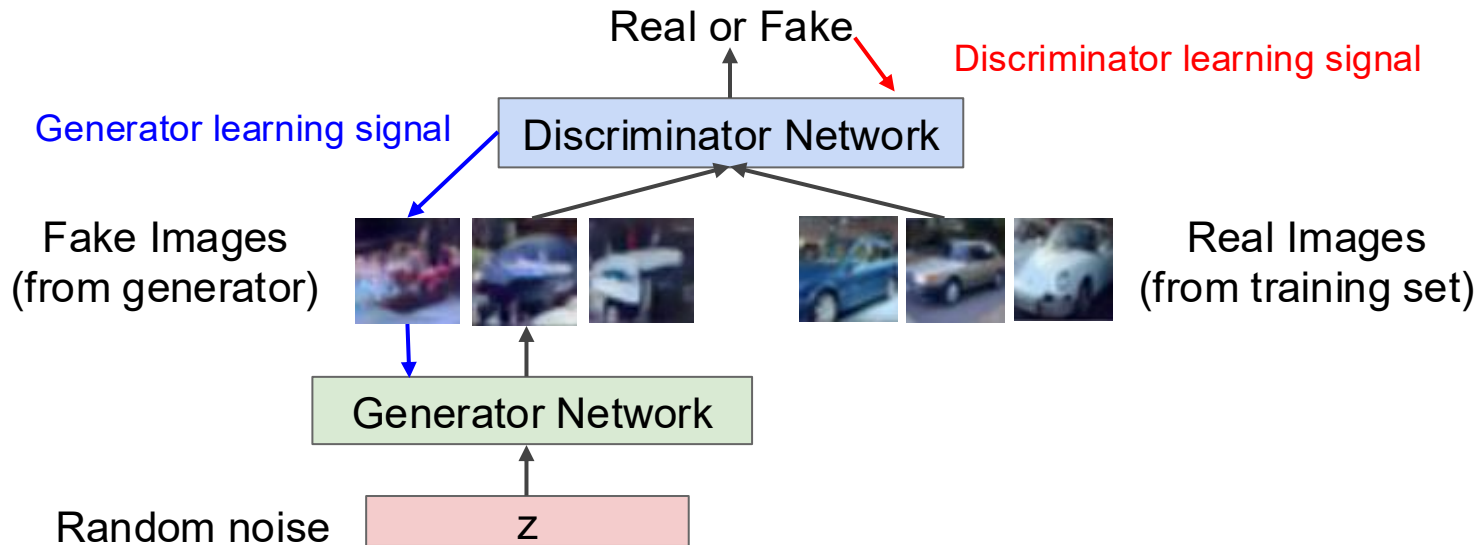

Fake and real images copyright Emily Denton et al. 2015. Reproduced with permission.

# Training GANs: Two-player game

Ian Goodfellow et al., "Generative Adversarial Nets", NIPS 2014

**Discriminator network:** try to distinguish between real and fake images

**Generator network:** try to fool the discriminator by generating real-looking images

Train jointly in **minimax game**

Minimax objective function:

$$\min_{\theta_g} \max_{\theta_d} \left[ \mathbb{E}_{x \sim p_{data}} \log D_{\theta_d}(x) + \mathbb{E}_{z \sim p(z)} \log(1 - D_{\theta_d}(G_{\theta_g}(z))) \right]$$

Generator objective      Discriminator objective

# Training GANs: Two-player game

Ian Goodfellow et al., "Generative Adversarial Nets", NIPS 2014

**Discriminator network:** try to distinguish between real and fake images

**Generator network:** try to fool the discriminator by generating real-looking images

Train jointly in **minimax game**

Minimax objective function:

$$\min_{\theta_g} \max_{\theta_d} \left[ \mathbb{E}_{x \sim p_{data}} \log \underbrace{D_{\theta_d}(x)}_{\substack{\text{Discriminator output} \\ \text{for real data } x}} + \mathbb{E}_{z \sim p(z)} \log(1 - \underbrace{D_{\theta_d}(G_{\theta_g}(z))}_{\substack{\text{Discriminator output for} \\ \text{generated fake data } G(z)}}) \right]$$

Discriminator outputs likelihood in (0,1) of real image

# Training GANs: Two-player game

Ian Goodfellow et al., "Generative Adversarial Nets", NIPS 2014

**Discriminator network:** try to distinguish between real and fake images

**Generator network:** try to fool the discriminator by generating real-looking images

Train jointly in **minimax game**

Minimax objective function:

$$\min_{\theta_g} \max_{\theta_d} \left[ \mathbb{E}_{x \sim p_{data}} \log \underbrace{D_{\theta_d}(x)}_{\substack{\text{Discriminator output} \\ \text{for real data } x}} + \mathbb{E}_{z \sim p(z)} \log(1 - \underbrace{D_{\theta_d}(G_{\theta_g}(z))}_{\substack{\text{Discriminator output for} \\ \text{generated fake data } G(z)}}) \right]$$

Discriminator outputs likelihood in (0,1) of real image

# Training GANs: Two-player game

Ian Goodfellow et al., "Generative Adversarial Nets", NIPS 2014

**Discriminator network:** try to distinguish between real and fake images

**Generator network:** try to fool the discriminator by generating real-looking images

Train jointly in **minimax game**

Minimax objective function:

Discriminator outputs likelihood in (0,1) of real image

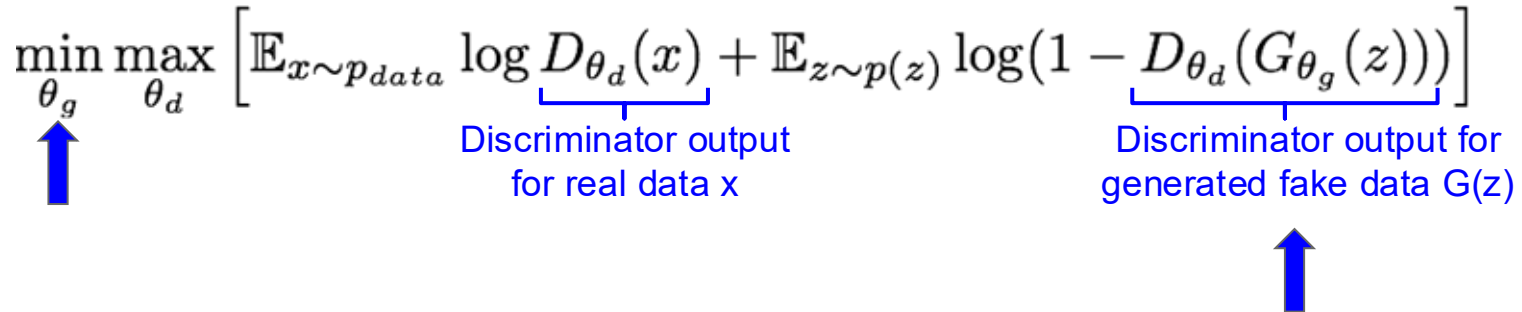
$$\min_{\theta_g} \max_{\theta_d} \left[ \mathbb{E}_{x \sim p_{data}} \log \underbrace{D_{\theta_d}(x)}_{\substack{\text{Discriminator output} \\ \text{for real data } x}} + \mathbb{E}_{z \sim p(z)} \log(1 - \underbrace{D_{\theta_d}(G_{\theta_g}(z))}_{\substack{\text{Discriminator output for} \\ \text{generated fake data } G(z)}}) \right]$$

# Training GANs: Two-player game

Ian Goodfellow et al., "Generative Adversarial Nets", NIPS 2014

**Discriminator network:** try to distinguish between real and fake images

**Generator network:** try to fool the discriminator by generating real-looking images

Train jointly in **minimax game**

Minimax objective function:

Discriminator outputs likelihood in (0,1) of real image

$$\min_{\theta_g} \max_{\theta_d} \left[ \mathbb{E}_{x \sim p_{data}} \log \underbrace{D_{\theta_d}(x)}_{\substack{\text{Discriminator output} \\ \text{for real data } x}} + \mathbb{E}_{z \sim p(z)} \log(1 - \underbrace{D_{\theta_d}(G_{\theta_g}(z))}_{\substack{\text{Discriminator output for} \\ \text{generated fake data } G(z)}}) \right]$$

- Discriminator ( $\theta_d$ ) wants to **maximize objective** such that  $D(x)$  is close to 1 (real) and  $D(G(z))$  is close to 0 (fake)
- Generator ( $\theta_g$ ) wants to **minimize objective** such that  $D(G(z))$  is close to 1 (discriminator is fooled into thinking generated  $G(z)$  is real)

# Training GANs: Two-player game

Ian Goodfellow et al., "Generative Adversarial Nets", NIPS 2014

Minimax objective function:

$$\min_{\theta_g} \max_{\theta_d} \left[ \mathbb{E}_{x \sim p_{data}} \log D_{\theta_d}(x) + \mathbb{E}_{z \sim p(z)} \log(1 - D_{\theta_d}(G_{\theta_g}(z))) \right]$$

Alternate between:

1. **Gradient ascent** on discriminator

$$\max_{\theta_d} \left[ \mathbb{E}_{x \sim p_{data}} \log D_{\theta_d}(x) + \mathbb{E}_{z \sim p(z)} \log(1 - D_{\theta_d}(G_{\theta_g}(z))) \right]$$

2. **Gradient descent** on generator

$$\min_{\theta_g} \mathbb{E}_{z \sim p(z)} \log(1 - D_{\theta_d}(G_{\theta_g}(z)))$$

# Training GANs: Two-player game

Ian Goodfellow et al., “Generative Adversarial Nets”, NIPS 2014

Minimax objective function:

$$\min_{\theta_g} \max_{\theta_d} \left[ \mathbb{E}_{x \sim p_{data}} \log D_{\theta_d}(x) + \mathbb{E}_{z \sim p(z)} \log(1 - D_{\theta_d}(G_{\theta_g}(z))) \right]$$

Alternate between:

1. **Gradient ascent** on discriminator

$$\max_{\theta_d} \left[ \mathbb{E}_{x \sim p_{data}} \log D_{\theta_d}(x) + \mathbb{E}_{z \sim p(z)} \log(1 - D_{\theta_d}(G_{\theta_g}(z))) \right]$$

2. **Gradient descent** on generator

$$\min_{\theta_g} \mathbb{E}_{z \sim p(z)} \log(1 - D_{\theta_d}(G_{\theta_g}(z)))$$

In practice, optimizing this generator objective does not work well!

When sample is likely fake, want to learn from it to improve generator (move to the right on X axis).

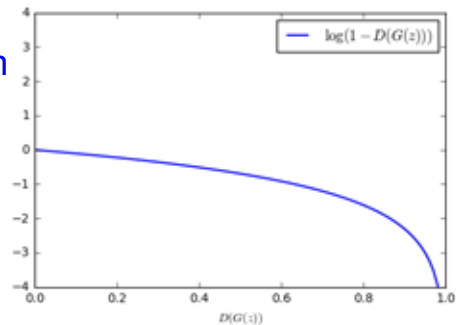

# Training GANs: Two-player game

Minimax objective function:

$$\min_{\theta_g} \max_{\theta_d} \left[ \mathbb{E}_{x \sim p_{data}} \log D_{\theta_d}(x) + \mathbb{E}_{z \sim p(z)} \log(1 - D_{\theta_d}(G_{\theta_g}(z))) \right]$$

Alternate between:

1. **Gradient ascent** on discriminator

$$\max_{\theta_d} \left[ \mathbb{E}_{x \sim p_{data}} \log D_{\theta_d}(x) + \mathbb{E}_{z \sim p(z)} \log(1 - D_{\theta_d}(G_{\theta_g}(z))) \right]$$

Gradient signal dominated by region where sample is already good

2. **Gradient descent** on generator

$$\min_{\theta_g} \mathbb{E}_{z \sim p(z)} \log(1 - D_{\theta_d}(G_{\theta_g}(z)))$$

When sample is likely fake, want to learn from it to improve generator (move to the right on X axis).

In practice, optimizing this generator objective does not work well!

But gradient in this region is relatively flat!

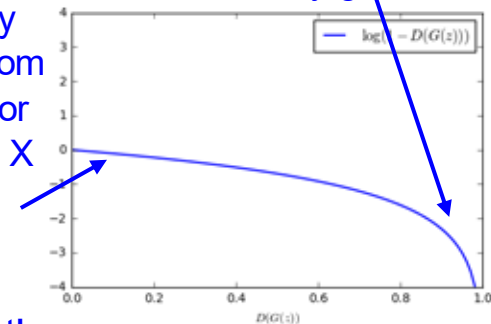

# Training GANs: Two-player game

Ian Goodfellow et al., “Generative Adversarial Nets”, NIPS 2014

Minimax objective function:

$$\min_{\theta_g} \max_{\theta_d} \left[ \mathbb{E}_{x \sim p_{data}} \log D_{\theta_d}(x) + \mathbb{E}_{z \sim p(z)} \log(1 - D_{\theta_d}(G_{\theta_g}(z))) \right]$$

Alternate between:

1. **Gradient ascent** on discriminator

$$\max_{\theta_d} \left[ \mathbb{E}_{x \sim p_{data}} \log D_{\theta_d}(x) + \mathbb{E}_{z \sim p(z)} \log(1 - D_{\theta_d}(G_{\theta_g}(z))) \right]$$

2. **Instead: Gradient ascent** on generator, **different objective**

$$\max_{\theta_g} \mathbb{E}_{z \sim p(z)} \log(D_{\theta_d}(G_{\theta_g}(z)))$$

Instead of minimizing likelihood of discriminator being correct, now maximize likelihood of discriminator being wrong.

Same objective of fooling discriminator, but now higher gradient signal for bad samples => works much better! Standard in practice.

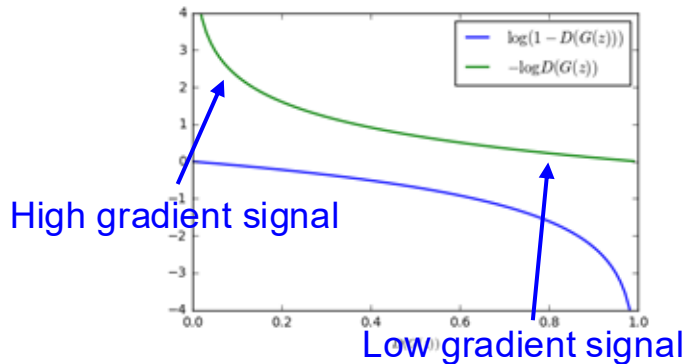

# Training GANs: Two-player game

Ian Goodfellow et al., “Generative Adversarial Nets”, NIPS 2014

## Putting it together: GAN training algorithm

**for** number of training iterations **do**

**for**  $k$  steps **do**

- Sample minibatch of  $m$  noise samples  $\{\mathbf{z}^{(1)}, \dots, \mathbf{z}^{(m)}\}$  from noise prior  $p_g(\mathbf{z})$ .
- Sample minibatch of  $m$  examples  $\{\mathbf{x}^{(1)}, \dots, \mathbf{x}^{(m)}\}$  from data generating distribution  $p_{\text{data}}(\mathbf{x})$ .
- Update the discriminator by ascending its stochastic gradient:

$$\nabla_{\theta_d} \frac{1}{m} \sum_{i=1}^m \left[ \log D_{\theta_d}(x^{(i)}) + \log(1 - D_{\theta_d}(G_{\theta_g}(z^{(i)}))) \right]$$

**end for**

- Sample minibatch of  $m$  noise samples  $\{\mathbf{z}^{(1)}, \dots, \mathbf{z}^{(m)}\}$  from noise prior  $p_g(\mathbf{z})$ .
- Update the generator by ascending its stochastic gradient (improved objective):

$$\nabla_{\theta_g} \frac{1}{m} \sum_{i=1}^m \log(D_{\theta_d}(G_{\theta_g}(z^{(i)})))$$

**end for**

# Training GANs: Two-player game

Ian Goodfellow et al., "Generative Adversarial Nets", NIPS 2014

## Putting it together: GAN training algorithm

**for** number of training iterations **do**

**for**  $k$  steps **do**

- Sample minibatch of  $m$  noise samples  $\{z^{(1)}, \dots, z^{(m)}\}$  from noise prior  $p_g(z)$ .
- Sample minibatch of  $m$  examples  $\{x^{(1)}, \dots, x^{(m)}\}$  from data generating distribution  $p_{\text{data}}(x)$ .
- Update the discriminator by ascending its stochastic gradient:

$$\nabla_{\theta_d} \frac{1}{m} \sum_{i=1}^m \left[ \log D_{\theta_d}(x^{(i)}) + \log(1 - D_{\theta_d}(G_{\theta_g}(z^{(i)}))) \right]$$

**end for**

- Sample minibatch of  $m$  noise samples  $\{z^{(1)}, \dots, z^{(m)}\}$  from noise prior  $p_g(z)$ .
- Update the generator by ascending its stochastic gradient (improved objective):

$$\nabla_{\theta_g} \frac{1}{m} \sum_{i=1}^m \log(D_{\theta_d}(G_{\theta_g}(z^{(i)})))$$

**end for**

Some find  $k=1$   
more stable,  
others use  $k > 1$ ,  
no best rule.

Followup work  
(e.g. Wasserstein  
GAN, BEGAN)  
alleviates this  
problem, better  
stability!

Arjovsky et al. "Wasserstein gan." arXiv preprint arXiv:1701.07875 (2017)

Berthelot, et al. "Began: Boundary equilibrium generative adversarial networks." arXiv preprint arXiv:1703.10717 (2017)

# Training GANs: Two-player game

Ian Goodfellow et al., "Generative Adversarial Nets", NIPS 2014

**Generator network:** try to fool the discriminator by generating real-looking images

**Discriminator network:** try to distinguish between real and fake images

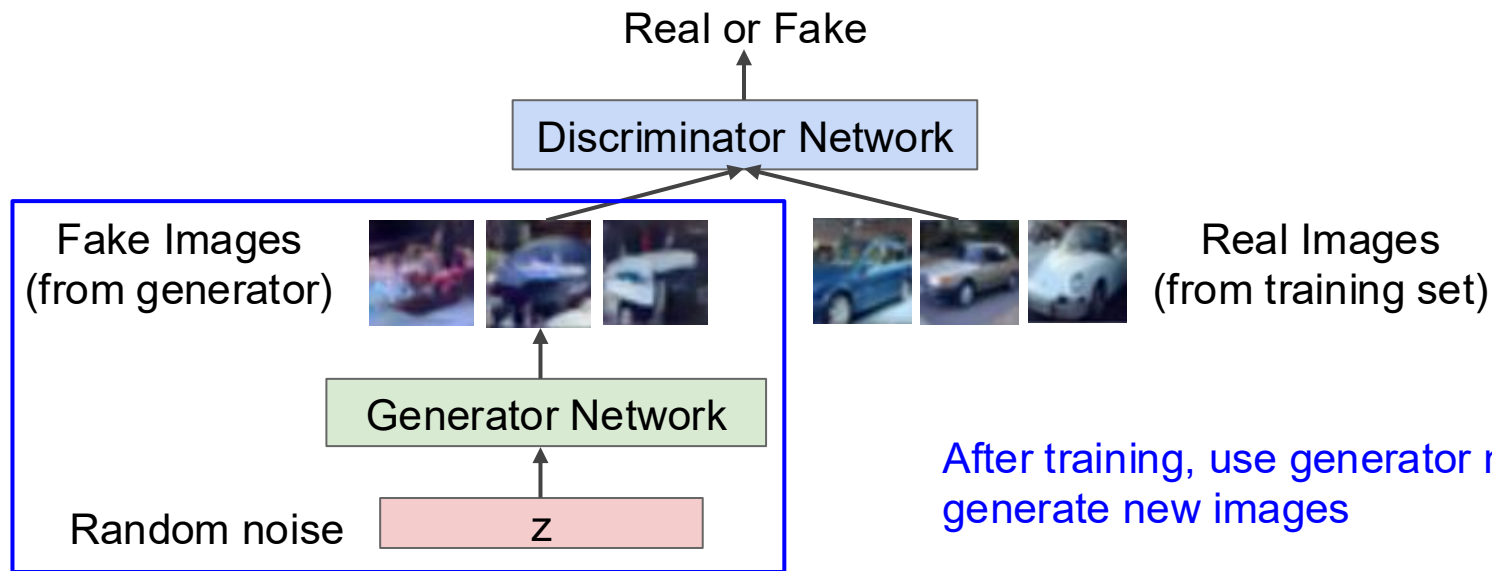

After training, use generator network to generate new images

Fake and real images copyright Emily Denton et al. 2015. Reproduced with permission.

# Generative Adversarial Nets

Generated samples

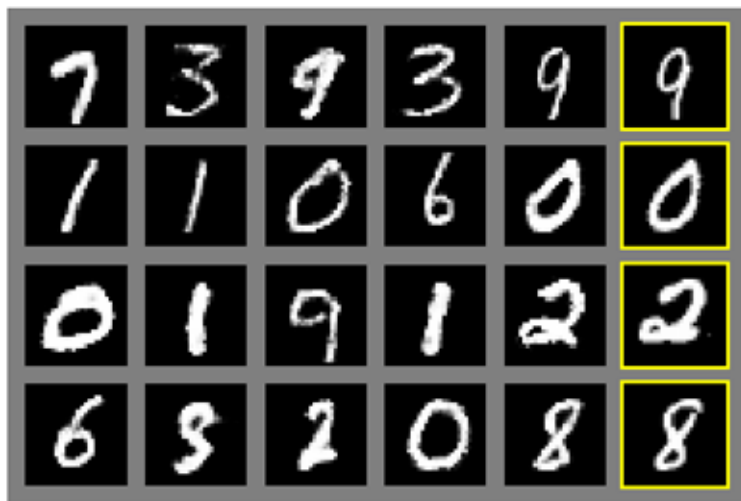

Nearest neighbor from training set

Figures copyright Ian Goodfellow et al., 2014. Reproduced with permission.

# Generative Adversarial Nets

## Generated samples (CIFAR-10)

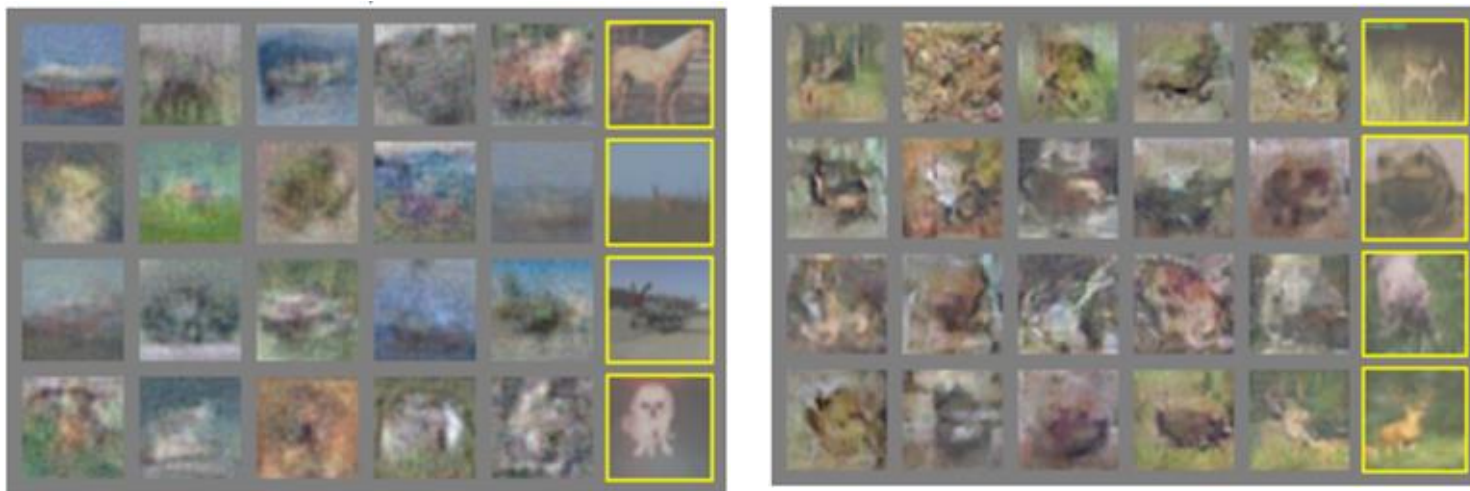

Nearest neighbor from training set

Figures copyright Ian Goodfellow et al., 2014. Reproduced with permission.

# Generative Adversarial Nets: Convolutional Architectures

Generator is an upsampling network with fractionally-strided convolutions  
Discriminator is a convolutional network

## Architecture guidelines for stable Deep Convolutional GANs

- Replace any pooling layers with strided convolutions (discriminator) and fractional-strided convolutions (generator).
- Use batchnorm in both the generator and the discriminator.
- Remove fully connected hidden layers for deeper architectures.
- Use ReLU activation in generator for all layers except for the output, which uses Tanh.
- Use LeakyReLU activation in the discriminator for all layers.

Radford et al, "Unsupervised Representation Learning with Deep Convolutional Generative Adversarial Networks", ICLR 2016

# Generative Adversarial Nets: Convolutional Architectures

Samples from the model look much better!



Radford et al,  
ICLR 2016

# Generative Adversarial Nets: Convolutional Architectures

Interpolating  
between  
random  
points in  
latent space



Radford et al,  
ICLR 2016

# Generative Adversarial Nets: Interpretable Vector Math

Radford et al, ICLR 2016

Smiling woman

Neutral woman

Neutral man

Samples  
from the  
model



# Generative Adversarial Nets: Interpretable Vector Math

Radford et al, ICLR 2016

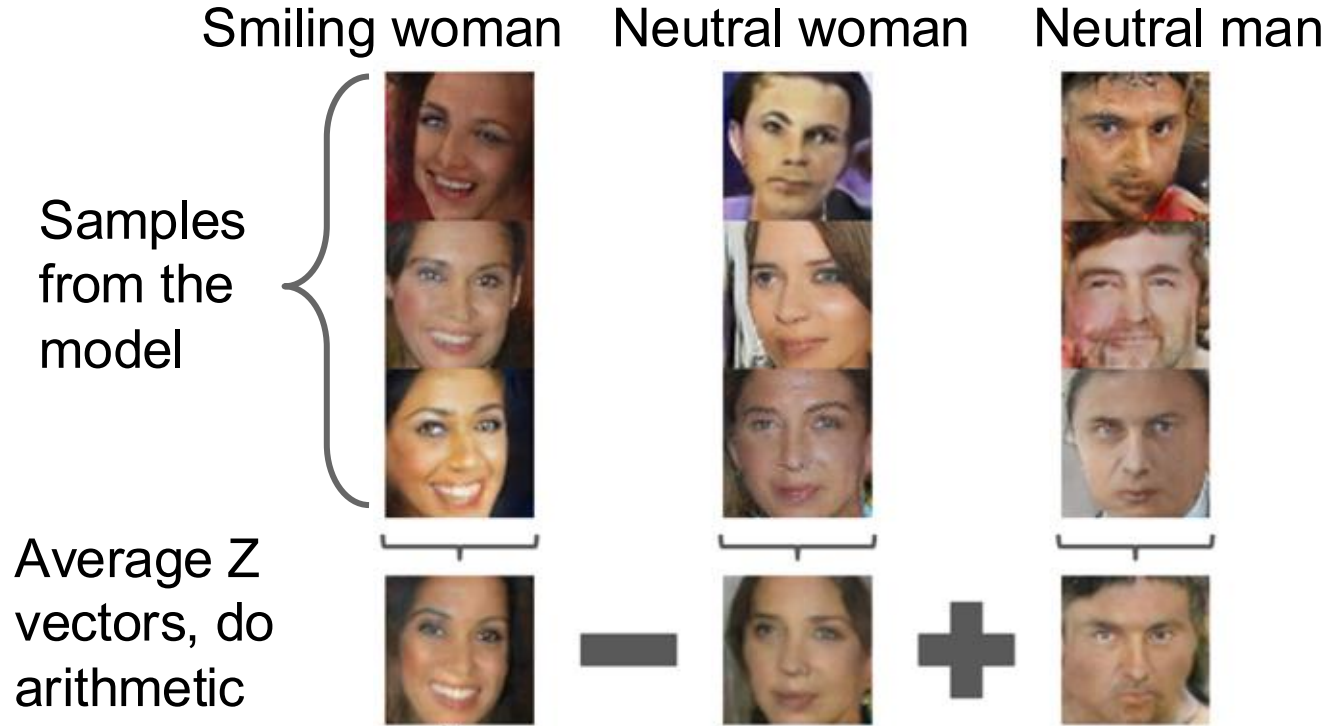

# Generative Adversarial Nets: Interpretable Vector Math

Radford et al, ICLR 2016

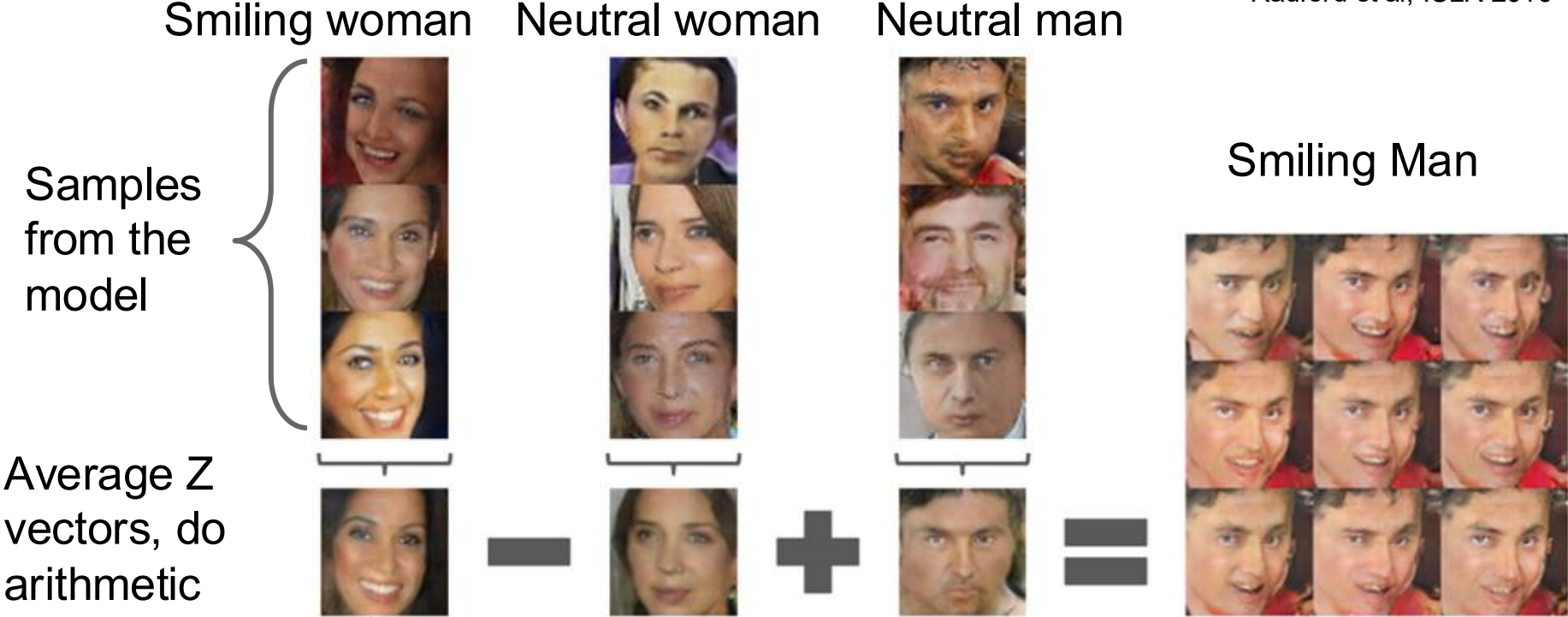

# Generative Adversarial Nets: Interpretable Vector Math

Glasses man



No glasses man



No glasses woman



-

+

=

Woman with glasses



Radford et al,  
ICLR 2016

# 2017: Explosion of GANs

## “The GAN Zoo”

See also: <https://github.com/soumith/ganhacks> for tips and tricks for trainings GANs

- GAN - Generative Adversarial Networks
- 3D-GAN - Learning a Probabilistic Latent Space of Object Shapes via 3D Generative-Adversarial Modeling
- acGAN - Face Aging With Conditional Generative Adversarial Networks
- AC-GAN - Conditional Image Synthesis With Auxiliary Classifier GANs
- AdaGAN - AdaGAN: Boosting Generative Models
- AEGAN - Learning Inverse Mapping by Autoencoder based Generative Adversarial Nets
- AffGAN - Amortised MAP Inference for Image Super-resolution
- AL-CGAN - Learning to Generate Images of Outdoor Scenes from Attributes and Semantic Layouts
- ALI - Adversarially Learned Inference
- AM-GAN - Generative Adversarial Nets with Labeled Data by Activation Maximization
- AnoGAN - Unsupervised Anomaly Detection with Generative Adversarial Networks to Guide Marker Discovery
- ArtGAN - ArtGAN: Artwork Synthesis with Conditional Categorical GANs
- b-GAN - b-GAN: Unified Framework of Generative Adversarial Networks
- Bayesian GAN - Deep and Hierarchical Implicit Models
- BEGAN - BEGAN: Boundary Equilibrium Generative Adversarial Networks
- BIGAN - Adversarial Feature Learning
- BS-GAN - Boundary-Seeking Generative Adversarial Networks
- CGAN - Conditional Generative Adversarial Nets
- CaloGAN - CaloGAN: Simulating 3D High Energy Particle Showers in Multi-Layer Electromagnetic Calorimeters with Generative Adversarial Networks
- CCGAN - Semi-Supervised Learning with Context-Conditional Generative Adversarial Networks
- CatGAN - Unsupervised and Semi-supervised Learning with Categorical Generative Adversarial Networks
- CoGAN - Coupled Generative Adversarial Networks
- Context-RNN-GAN - Contextual RNN-GANs for Abstract Reasoning Diagram Generation
- C-RNN-GAN - C-RNN-GAN: Continuous recurrent neural networks with adversarial training
- CS-GAN - Improving Neural Machine Translation with Conditional Sequence Generative Adversarial Nets
- CVAE-GAN - CVAE-GAN: Fine-Grained Image Generation through Asymmetric Training
- CycleGAN - Unpaired Image-to-Image Translation using Cycle-Consistent Adversarial Networks
- DTN - Unsupervised Cross-Domain Image Generation
- DCGAN - Unsupervised Representation Learning with Deep Convolutional Generative Adversarial Networks
- DiscoGAN - Learning to Discover Cross-Domain Relations with Generative Adversarial Networks
- DR-GAN - Disentangled Representation Learning GAN for Pose-Invariant Face Recognition
- DualGAN - DualGAN: Unsupervised Dual Learning for Image-to-Image Translation
- EBGAN - Energy-based Generative Adversarial Network
- f-GAN - f-GAN: Training Generative Neural Samplers using Variational Divergence Minimization
- FF-GAN - Towards Large-Pose Face Frontalization in the Wild
- GAWWN - Learning What and Where to Draw
- GeneGAN - GeneGAN: Learning Object Transfiguration and Attribute Subspace from Unpaired Data
- Geometric GAN - Geometric GAN
- GoGAN - Gang of GANs: Generative Adversarial Networks with Maximum Margin Ranking
- GP-GAN - GP-GAN: Towards Realistic High-Resolution Image Blending
- IAN - Neural Photo Editing with Introspective Adversarial Networks
- iGAN - Generative Visual Manipulation on the Natural Image Manifold
- IcGAN - Invertible Conditional GANs for image editing
- ID-CGAN - Image De-raining Using a Conditional Generative Adversarial Network
- Improved GAN - Improved Techniques for Training GANs
- InfoGAN - InfoGAN: Interpretable Representation Learning by Information Maximizing Generative Adversarial Nets
- LAGAN - Learning Particle Physics by Example: Location-Aware Generative Adversarial Networks for Physics Synthesis
- LAPGAN - Deep Generative Image Models using a Laplacian Pyramid of Adversarial Networks

<https://github.com/hindupuravinash/the-gan-zoo>

# 2017: Explosion of GANs

## Better training and generation



LSGAN, Zhu 2017.



Wasserstein GAN,  
Arjovsky 2017.  
Improved Wasserstein  
GAN, Gulrajani 2017.



Progressive GAN, Karras 2018.

# 2017: Explosion of GANs

Source->Target domain transfer

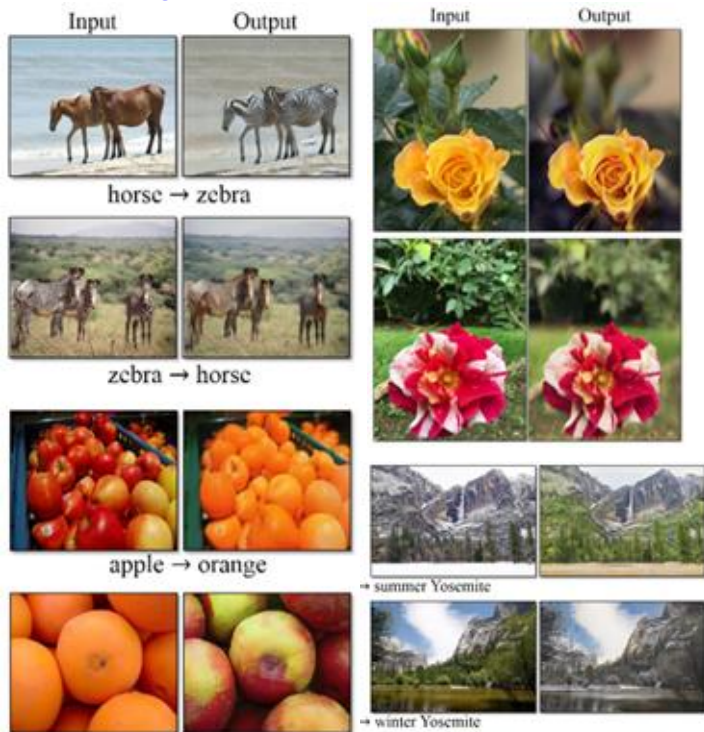

CycleGAN. Zhu et al. 2017.

## Text -> Image Synthesis

this small bird has a pink breast and crown, and black primaries and secondaries.

this magnificent fellow is almost all black with a red crest, and white cheek patch.



Reed et al. 2017.

## Many GAN applications



Pix2pix. Isola 2017. Many examples at <https://phillipi.github.io/pix2pix/>

# 2019: BigGAN



Brock et al., 2019

# Summary: GANs

Don't work with an explicit density function

Take game-theoretic approach: learn to generate from training distribution through 2-player game

Pros:

- Beautiful, state-of-the-art samples!

Cons:

- Trickier / more unstable to train
- Can't solve inference queries such as  $p(x)$ ,  $p(z|x)$

Active areas of research:

- Better loss functions, more stable training (Wasserstein GAN, LSGAN, many others)
- Conditional GANs, GANs for all kinds of applications

# Summary

## Autoregressive models: PixelRNN, PixelCNN

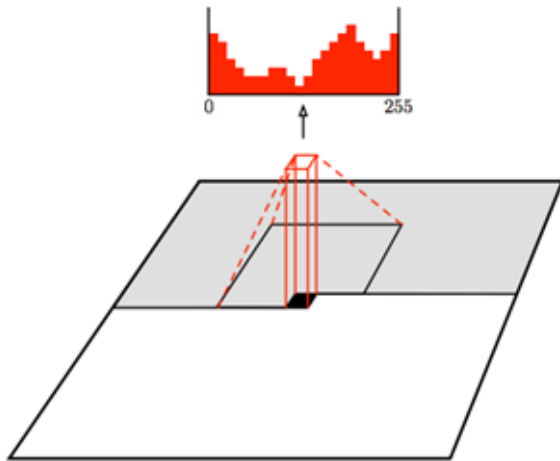

Van der Oord et al, "Conditional image generation with pixelCNN decoders", NIPS 2016

## Variational Autoencoders

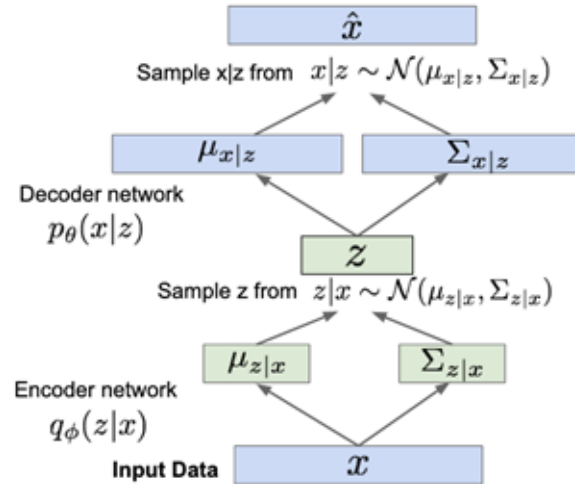

Kingma and Welling, "Auto-encoding variational bayes", ICLR 2013

## Generative Adversarial Networks (GANs)

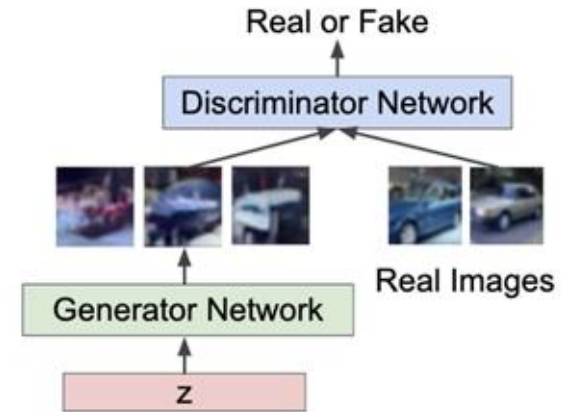

Goodfellow et al, "Generative Adversarial Nets", NIPS 2014